

Key: 2157

Town of CHATHAM - Fiscal Year 2024

9/7/2023 9:38 am SEQ #: 2.334

LEG
AL
LAND

CURRENT OWNER				PARCEL ID				LOCATION				
18 ATTUCKS TRAIL LLC 2117 DELANCEY ST PHILADELPHIA, PA 19103				14A2-4-N58				18 ATTUCKS TRL				
TRANSFER HISTORY				DOS	T	SALE PRICE	BK-PG (Cert)					
18 ATTUCKS TRAIL LLC				12/01/2021	V	3,800,000	(228429)					
RUMA MARICA L				11/06/2009	A	1	(190011)					
RUMA CHARLES J & MARCIA L				02/16/1977	N	54,249	(69811)					
CD	T	AC/SF/UN	Nbhd	Inf1	Inf2	ADJ BASE	SAF	Inf3	Lpi	VC	CREDIT AMT	ADJ VALUE
100	S	40,000	MOR 1.00	100	1.00	2,199,000	1.00	100	1.00	W10	6.00	2,019,280
300	A	0.681	MOR 1.00	100	1.00	115,200	1.00	100	1.00	W10	6.00	78,450

CLASS	CLASS%	DESCRIPTION			BN ID	BN	CARD	
1010	100	SINGLE FAMILY				1	1 of 1	
PMT NO	PMT DT	TY	DESC	AMOUNT	INSP	BY	1st	%
14-415	07/16/2014	2	Additions	25,000	04/29/2015	MW	100	100
14-232	04/30/2014	11	Window Rplc	25,000	04/29/2015	MW	100	100
	05/12/2008	50	Meas & List			RRC	100	100
	03/02/2002	50	Meas & List			JB	100	100
2000100	03/27/2000	99	n/a				100	100

DET
ACHED

TOTAL	1.599 Acres	ZONING	R40	FRNT	0	ASSESSED	CURRENT	PREVIOUS
Nbhd	MORRIS ISLAND	NOTE				LAND	2,097,700	1,456,700
Inf1	100		BUILDING	1,181,200	1,075,000			
Inf2	100		DETACHED	0	0			
			OTHER	0	0			
						TOTAL	3,278,900	2,531,700

TY	QUAL	COND	DIM/NOTE	YB	UNITS	ADJ PRICE	RCNLD



BLDG COMMENTS

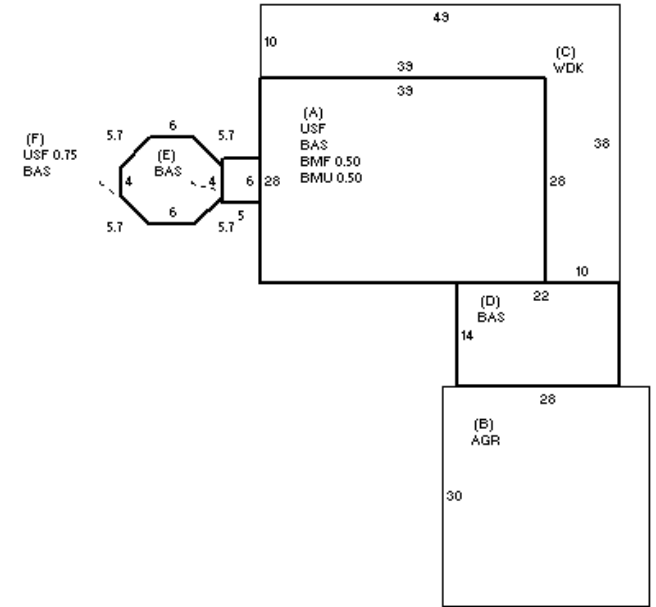

B
U
I
L
D
I
N
G

BUILDING	CD	ADJ	DESC	MEASURE		
MODEL	1		RESIDENTIAL	LIST		
STYLE	5	1.00	COLONIAL [100%]	REVIEW	9/20/2021	APK
QUALITY	G	1.55	GOOD [100%]			
FRAME	1	1.00	WOOD FRAME [100%]			

YEAR BLT	1975	SIZE ADJ	1.000	ELEMENT	CD	DESCRIPTION	ADJ	S	BAT	T	DESCRIPTION	UNITS	YB	ADJ PRICE	RCN	TOTAL RCN	1,357,751	
NET AREA	2,760	DETAIL ADJ	1.060	FOUNDATION	4	FLR & WALL	1.00	A	BMU	N	BSMT UNFINISHED	546		133.77	73,039			
\$NLA(RCN)	\$492	OVERALL	1.000	EXT. COVER	1	WOOD SHINGLE	1.00	A	BMF	N	BSMT FINISH-SEP	546		168.33	91,909			
				ROOF SHAPE	1	GABLE	1.00	+	USF	L	UP-STRY FIN	1,194	1975	324.53	387,488			
				ROOF COVER	2	WOOD SHIN	1.01	B	AGR	N	ATTACHED GARAGE	840		115.97	97,416			
				FLOOR COVER	23	SOFTWD/CARPET	1.00	C	WDK	N	WOOD DECK	770		90.52	69,700			
				INT. FINISH	2	DRYWALL	1.00	+	BAS	L	BAS AREA	1,566	1975	382.46	598,929			
				HEATING/COOL	11	HT-WT/COOL AIR	1.05	F22	O	FPL 2S 2OP	1			22,521.50	22,522			
				FUEL SOURCE	2	GAS	1.00	GEN	O	GENERATOR	1			0.00				
								ODS	O	OUT DOOR SHWR-A	1			2,289.40	2,289			
																EFF.YR/AGE	2009 / 13	
																COND	13 13%	
																FUNC	0	
																ECON	0	
																DEPR	13 % GD 87	
																RCNLD	\$1,181,200	