

Key: 2607

Town of CHATHAM - Fiscal Year 2024

9/7/2023 9:38 am SEQ #: 2.814

LEG  
AL  
LAND

CURRENT OWNER				PARCEL ID				LOCATION			
LEWIS MARIANNE 21 COD LN CHATHAM, MA 02633				14G-62-B100				21 COD LN			
TRANSFER HISTORY				DOS	T	SALE PRICE	BK-PG (Cert)				
LEWIS MARIANNE				10/15/1998	99	127,000	11761-25				
JONES				10/01/1985	QS	85,000	4735-38				

CLASS	CLASS%	DESCRIPTION			BN ID	BN	CARD	
1010	100	SINGLE FAMILY				1	1 of 1	
PMT NO	PMT DT	TY	DESC	AMOUNT	INSP	BY	1st	%
1998193	02/12/2008 09/09/1998	50 99	Meas & List n/a			RRC	100 100	100 100

CD	T	AC/SF/UN	Nbhd	Inf1	Inf2	ADJ BASE	SAF	Inf3	Lpi	VC	CREDIT AMT	ADJ VALUE
100	S	11,500	MC	1.00	100 1.00	439,800	2.84	100 1.00	R06	1.20		329,950

TOTAL	11,500 SF	ZONING	R40	FRNT	208	ASSESSED	CURRENT	PREVIOUS
Nbhd	MID CHATHAM	NOTE			LAND	330,000	274,900	
Inf1	100		BUILDING	266,000	241,900			
Inf2	100		DETACHED	0	0			
			OTHER	0	0			
			<b>TOTAL</b>	<b>596,000</b>	<b>516,800</b>			

DETACHED

TY	QUAL	COND	DIM/NOTE	YB	UNITS	ADJ PRICE	RCNLD

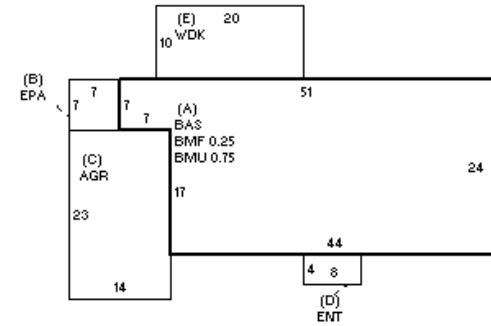

BUILDING	CD	ADJ	DESC	MEASURE	10/19/2021	NF
MODEL	1		RESIDENTIAL	LIST	10/19/2021	EST
STYLE	1	0.85	RANCH [100%]	REVIEW	12/1/2021	EMZ
QUALITY	A	1.00	AVERAGE [100%]			
FRAME	1	1.00	WOOD FRAME [100%]			

BUILDING

YEAR BLT	1961	SIZE ADJ	1.000	ELEMENT	CD	DESCRIPTION	ADJ	S	BAT	T	DESCRIPTION	UNITS	YB	ADJ PRICE	RCN	TOTAL RCN	415,583
NET AREA	1,105	DETAIL ADJ	0.850	FOUNDATION	4	FLR & WALL	1.00	A	BMU	N	BSMT UNFINISHED	829		75.86	62,891		
\$NLA(RCN)	\$376	OVERALL	1.000	EXT. COVER	1	WOOD SHINGLE	1.00	A	BMF	N	BSMT FINISH-SEP	276		108.60	29,974		
CAPACITY		UNITS	ADJ	ROOF SHAPE	1	GABLE	1.00	A	BAS	L	BAS AREA	1,105	1961	237.52	262,462		
STORIES	1	1.00		ROOF COVER	1	ASPH/CMP SHIN	1.00	B	EPA	N	ENCL PORCH	49		133.69	6,551		
ROOMS	6	1.00		FLOOR COVER	14	HARDWD/ASPH TL	1.00	C	AGR	N	ATTACHED GARAGE	322		83.08	26,753		
BEDROOMS	3	1.00		INT. FINISH	2	DRYWALL	1.00	D	ENT	N	ENCL ENTRY	32		133.69	4,278		
FULL BATHS	1	1.00		HEATING/COOL	2	HOT WATER	1.00	E	WDK	N	WOOD DECK	200		58.40	11,680		
1/2 BATHS	0	1.00		FUEL SOURCE	2	GAS	1.00		F11	O	FPL 1S 1OP	1		7,477.00	7,477		
FIXTURES	3	\$2,040							ODS	O	OUT DOOR SHWR-A	1		1,477.00	1,477		
UNITS	1	1.00															
																<b>EFF.YR/AGE</b>	1968 / 54
																<b>COND</b>	36 36 %
																<b>FUNC</b>	0
																<b>ECON</b>	0
																<b>DEPR</b>	36 % GD 64
																<b>RCNLD</b>	\$266,000