

Key: 2624

Town of CHATHAM - Fiscal Year 2024

9/7/2023 9:38 am SEQ #: 2.831

LEGALS AND

Table with columns: CURRENT OWNER, PARCEL ID, LOCATION, TRANSFER HISTORY, DOS, T, SALE PRICE, BK-PG (Cert). Includes owner name DUNNE ANDREW III & LINDA B and parcel details.

Table with columns: CLASS, CLASS%, DESCRIPTION, BN ID, BN, CARD. Includes details for class 1010 and description SINGLE FAMILY.

Table with columns: CD, T, AC/SF/UN, Nbhd, Infl1, Infl2, ADJ BASE, SAF, Infl3, Lpi, VC, CREDIT AMT, ADJ VALUE. Includes values for 100 S, 7,821 SF, and 143,880 ADJ VALUE.

Table with columns: TOTAL, ZONING, R20, FRNT, 118, ASSESSED, CURRENT, PREVIOUS. Includes assessed values for LAND, BUILDING, DETACHED, and OTHER.

Table with columns: TY, QUAL, COND, DIM/NOTE, YB, UNITS, ADJ PRICE, RCNLD. Includes rows for SHF (Shed) with dimensions 6X8, 5X7, and 6X8.

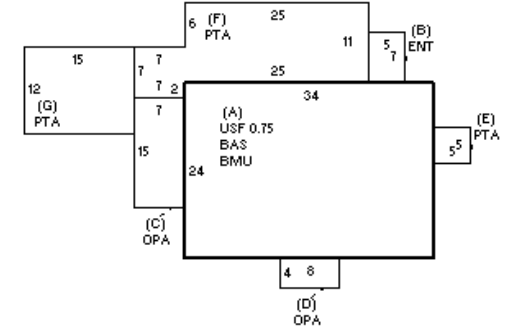

Table with columns: BUILDING, CD, ADJ, DESC, MEASURE, 1/6/2022, NF. Includes building details like RESIDENTIAL, COLONIAL [100%], and WOOD FRAME [100%].

BLDG COMMENTS: INFO @ DOOR 1/5/22

BUILDING

Table with columns: YEAR BLT, NET AREA, \$NLA(RCN), CAPACITY, UNITS, ADJ. Includes values for 1988, 1,428, \$247, 1.75, 7, 3, 2, 0, 3, 1.

Table with columns: ELEMENT, CD, DESCRIPTION, ADJ. Lists building elements like FOUNDATION, EXT. COVER, ROOF SHAPE, etc.

Table with columns: S, BAT, T, DESCRIPTION, UNITS, YB, ADJ PRICE, RCN. Lists building systems like BSMT UNFINISHED, BAS AREA, UP-STRY FIN, etc.

Table with columns: TOTAL RCN, CONDITION ELEM, CD, EFF.YR/AGE, COND, FUNC, ECON, DEPR, RCNLD. Includes values for 352,115, 1988 / 34, 25 25%, 0, 25 AFFORD, 50 % GD, 50, \$176,100.