

Key: 2828

Town of CHATHAM - Fiscal Year 2024

9/7/2023 9:38 am SEQ #: 3.055

LEGAL

LAND

DETACHED

BUILDING

CURRENT OWNER				PARCEL ID				LOCATION			
DE PAPP JOHN W & GABRIELLE L 25 HAMDEN PL N CHATHAM, MA 02650				14J-1B-1B				25 HAMDEN PL			
TRANSFER HISTORY				DOS	T	SALE PRICE	BK-PG (Cert)				
DE PAPP JOHN W & GABRIELLE				07/03/2019	QS	1,265,000	32137-253				
25 HAMDEN PLACE LLC				12/27/2017	B	1	30988-198				
GENERAL GROWTH HOLDINGS L				06/06/2014	P	310,000	28187-319				

CD	T	AC/SF/UN	Nbhd	Inf1	Inf2	ADJ BASE	SAF	Inf3	Lpi	VC	CREDIT AMT	ADJ VALUE
100	S	40,000	NC	1.00	100	1.00	100	1.00	R05	1.30		437,510
300	A	0.001	NC	1.00	100	1.00	100	1.00	R05	1.30		20

TOTAL	40,049 SF	ZONING	R40	FRNT	0	ASSESSED	CURRENT	PREVIOUS
Nbhd	NORTH CHATHAM	NOTE	LAND	437,500	364,600			
Inf1	100		BUILDING	1,273,800	1,171,800			
Inf2	100		DETACHED	0	0			
			OTHER	0	0			
TOTAL			TOTAL	1,711,300	1,536,400			

TY	QUAL	COND	DIM/NOTE	YB	UNITS	ADJ PRICE	RCNLD



BLDG COMMENTS		
LLF=1FBTH,2 RMS		

BUILDING	CD	ADJ	DESC	MEASURE	6/22/2016	WFF
MODEL	1		RESIDENTIAL	LIST	6/22/2016	WFF
STYLE	4	1.00	CAPE [100%]	REVIEW	9/7/2021	APK
QUALITY	G	1.55	GOOD [100%]			
FRAME	1	1.00	WOOD FRAME [100%]			

CLASS	CLASS%	DESCRIPTION			BN ID	BN	CARD	
1010	100	SINGLE FAMILY				1	1 of 1	
PMT NO	PMT DT	TY	DESC	AMOUNT	INSP	BY	1st	%
21-39PLUMB	01/21/2021	2	Additions		09/17/2021	APK	100	100
14-778	10/21/2019	98	SALES QUESTI				100	100
	12/17/2014	1	New Construc	600,000	01/29/2019	TCK	100	100

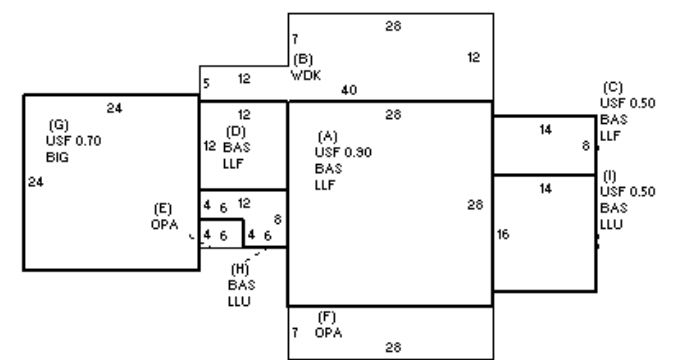

YEAR BLT	2015	SIZE ADJ	1.000	ELEMENT	CD	DESCRIPTION	ADJ	S	BAT	T	DESCRIPTION	UNITS	YB	ADJ PRICE	RCN	TOTAL RCN	1,369,715	
NET AREA	2,613	DETAIL ADJ	1.030	FOUNDATION	4	FLR & WALL	1.00	+	LLF	N	LOWER LEVEL FIN	1,040		262.53	273,033	CONDITION ELEM	CD	
\$NLA(RCN)	\$524	OVERALL	1.000	EXT. COVER	1	WOOD SHINGLE	1.00	+	BAS	L	BAS AREA	1,336	2015	356.74	476,600	EXTERIOR	A	
				ROOF SHAPE	1	GABLE	1.00	+	USF	L	UP-STRY FIN	874	2015	302.70	264,562	INTERIOR	A	
				ROOF COVER	1	ASPH/CMP SHIN	1.00	B	WDK	N	WOOD DECK	396		90.52	35,845	KITCHEN	A	
				FLOOR COVER	1	HARDWOOD	1.00	+	OPA	N	OPEN PORCH	220		117.96	25,950	BATHS	A	
				INT. FINISH	2	DRYWALL	1.00	G	BIG	N	BUILT-IN GARAGE	576		119.61	68,896	HEAT	A	
				HEATING/COOL	9	WARM/COOL AIR	1.03	G	USF	L	UP-STRY FIN	403	2016	302.70	121,990	ELECT	A	
				FUEL SOURCE	2	GAS	1.00	+	LLU	N	LOWER LEVEL UN	296		201.00	59,497			
								F21	O	FPL	2S	IOP	1		16,082.80	16,083		
								GFP	O	GAS	LOG/FP/E	FP	1		9,644.10	9,644		
								ODS	O	OUT	DOOR	SHWR-A	1		2,289.40	2,289		
														EFF.YR/AGE	2015 / 7			
														COND	7 7 %			
														FUNC	0			
														ECON	0			
														DEPR	7 % GD 93			
														RCNLD	\$1,273,800			