

Key: 2849

Town of CHATHAM - Fiscal Year 2024

9/7/2023 9:38 am SEQ #: 3.077

LEGAL

LAND

DETACHED

BUILDING

| CURRENT OWNER | | | | PARCEL ID | | | | LOCATION | | | |
|---|--|--|--|------------|----|------------|--------------|-----------------|--|--|--|
| SCOTT R & CAROLINE LANE 2016 TRUSTS LANE SCOTT & CAROLINE S TRSTES 52 WENTWORTH LN N CHATHAM, MA 02650 | | | | 14J-38-R46 | | | | 52 WENTWORTH LN | | | |
| TRANSFER HISTORY | | | | DOS | T | SALE PRICE | BK-PG (Cert) | | | | |
| SCOTT R & CAROLINE LANE 2 | | | | 07/11/2016 | A | 1 | 29788-102 | | | | |
| LANE SCOTT R & CAROLINE | | | | 07/12/2010 | QS | 626,500 | 24674-243 | | | | |
| GORDON BEATRICE B ESTATE | | | | 12/16/1980 | 99 | 100 | 3210-147 | | | | |

| CLASS | CLASS% | DESCRIPTION | | | BN ID | BN | CARD | |
|--------|------------|---------------|--------------|---------|------------|-----|--------|-----|
| 1010 | 100 | SINGLE FAMILY | | | | 1 | 1 of 1 | |
| PMT NO | PMT DT | TY | DESC | AMOUNT | INSP | BY | 1st | % |
| 23-401 | 06/02/2023 | 3 | Renovations | 100,000 | | | | 0 |
| 19-455 | 06/20/2019 | 3 | Renovations | 60,000 | 02/11/2020 | TCK | 100 | 100 |
| 16-299 | 05/11/2016 | 3 | Renovations | 1,700 | 07/13/2018 | NF | 100 | 100 |
| 16-221 | 04/14/2016 | 77 | SOLAR PANELS | 19,000 | 05/26/2017 | NF | 100 | 100 |
| 16-156 | 03/22/2016 | 3 | Renovations | 124,000 | 05/26/2017 | NF | 100 | 100 |

| CD | T | AC/SF/UN | Nbhd | Inf1 | Inf2 | ADJ BASE | SAF | Inf3 | Lpi | VC | CREDIT AMT | ADJ VALUE |
|-----|---|----------|------|------|------|----------|------|------|------|-----|------------|-----------|
| 100 | S | 20,480 | NC | 1.00 | 1.00 | 733,000 | 1.74 | 1.00 | 1.00 | R09 | 2.00 | 599,850 |

| | | | | | | | | |
|-------|---------------|--|----------|-----------|---------|----------|---------|----------|
| TOTAL | 20,480 SF | ZONING | R40 | FRNT | 0 | ASSESSED | CURRENT | PREVIOUS |
| Nbhd | NORTH CHATHAM | NOTE RYDERS COVE ASSOC.=DOCK,POOL,TENNIS COURTS | LAND | 599,900 | 499,900 | | | |
| Inf1 | 100 | | BUILDING | 617,800 | 465,200 | | | |
| Inf2 | 100 | | DETACHED | 1,200 | 1,200 | | | |
| | | | OTHER | 0 | 0 | | | |
| TOTAL | | | | 1,218,900 | 966,300 | | | |

| TY | QUAL | COND | DIM/NOTE | YB | UNITS | ADJ PRICE | RCNLD |
|-----|------|------|--------------|------|-------|-----------|-------|
| SHF | A | 1.00 | 10 0.90 12X8 | 2016 | 96 | 14.26 | 1,200 |

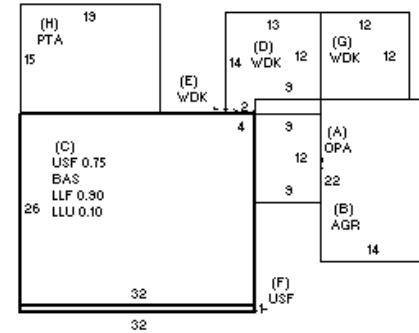

| BUILDING | CD | ADJ | DESC | MEASURE | LIST | REVIEW |
|----------|----|------|-------------------|---------|------|--------|
| MODEL | 1 | | RESIDENTIAL | | | |
| STYLE | 5 | 1.00 | COLONIAL [100%] | | | |
| QUALITY | + | 1.20 | PLUS AVE [100%] | | | |
| FRAME | 1 | 1.00 | WOOD FRAME [100%] | | | |

BLDG COMMENTS

LLF=FAM RM/BR/BATH (PER OWNER 2/11/20)
20 SOLAR PANELS

| YEAR BLT | 1972 | SIZE ADJ | 1.000 | ELEMENT | CD | DESCRIPTION | ADJ | S | BAT | T | DESCRIPTION | UNITS | YB | ADJ PRICE | RCN | TOTAL RCN | 694,104 |
|------------|-------|------------|-------|--------------|----|----------------|------|---|-----|---|-----------------|-------|------|-----------|---------|----------------|------------|
| NET AREA | 1,488 | DETAIL ADJ | 1.050 | FOUNDATION | 4 | FLR & WALL | 1.00 | A | OPA | N | OPEN PORCH | 108 | | 91.32 | 9,863 | CONDITION ELEM | CD |
| \$NLA(RCN) | \$466 | OVERALL | 1.000 | EXT. COVER | 1 | WOOD SHINGLE | 1.00 | B | AGR | N | ATTACHED GARAGE | 308 | | 100.43 | 30,934 | EXTERIOR | A |
| | | | | ROOF SHAPE | 6 | SALTBOX | 1.00 | C | LLU | N | LOWER LEVEL UN | 83 | | 169.56 | 14,074 | INTERIOR | V |
| | | | | ROOF COVER | 1 | ASPH/CMP SHIN | 1.00 | C | LLF | N | LOWER LEVEL FIN | 749 | | 221.46 | 165,875 | KITCHEN | V |
| | | | | FLOOR COVER | 1 | HARDWOOD | 1.00 | C | BAS | L | BAS AREA | 832 | 1972 | 300.93 | 250,374 | BATHS | V |
| | | | | INT. FINISH | 2 | DRYWALL | 1.00 | + | WDK | N | WOOD DECK | 326 | | 70.08 | 22,846 | HEAT | U |
| | | | | HEATING/COOL | 11 | HT-WT/COOL AIR | 1.05 | + | USF | L | UP-STRY FIN | 656 | 1972 | 255.35 | 167,509 | ELECT | U |
| | | | | FUEL SOURCE | 2 | GAS | 1.00 | H | PTA | N | PATIO/STOOP | 285 | | 21.48 | 6,122 | | |
| | | | | | | | | | F22 | O | FPL 2S ZOP | 1 | | 17,436.00 | 17,436 | | |
| | | | | | | | | | | | | | | | | EFF.YR/AGE | 2011 / 11 |
| | | | | | | | | | | | | | | | | COND | 11 11 % |
| | | | | | | | | | | | | | | | | FUNC | 0 |
| | | | | | | | | | | | | | | | | ECON | 0 |
| | | | | | | | | | | | | | | | | DEPR | 11 % GD 89 |
| | | | | | | | | | | | | | | | | RCNLD | \$617,800 |