

Key: 3444

Town of CHATHAM - Fiscal Year 2024

9/7/2023 9:38 am SEQ #: 3.737

LEGAL LAND

Table with columns: CURRENT OWNER, PARCEL ID, LOCATION, TRANSFER HISTORY, DOS, T, SALE PRICE, BK-PG (Cert). Includes owner SHELLIE S LOVALLO TRUST 2012 and transfer history from 12/28/2012 to 11/09/1978.

Table with columns: CLASS, CLASS%, DESCRIPTION, BN ID, BN, CARD. Includes multiple HSES entries for PMT NO 1090, 100, 109-481 with descriptions like Additions, Renovations, Meas, Pools etc.

Table with columns: CD, T, AC/SF/UN, Nbhd, Inf1, Inf2, ADJ BASE, SAF, Inf3, Lpi, VC, CREDIT AMT, ADJ VALUE. Includes totals for assessed, current, and previous values.

Table with columns: TY, QUAL, COND, DIM/NOTE, YB, UNITS, ADJ PRICE, RCNLD. Includes rows for IPG, PTD, and various building details.

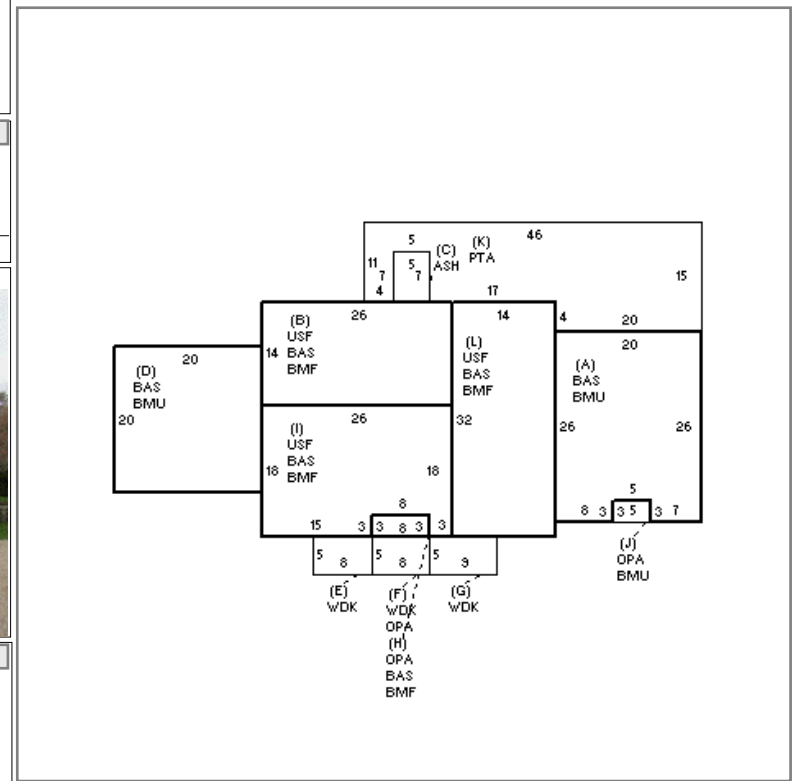

Table with columns: BUILDING, CD, ADJ, DESC, MEASURE, LIST, REVIEW. Includes building details like MODEL 1, STYLE 5, QUALITY V, and FRAME 1.

Table with columns: YEAR BLT, SIZE ADJ, NET AREA, \$NLA(RCN), CAPACITY, UNITS, ADJ. Includes capacity breakdown for stories, rooms, bedrooms, full baths, 1/2 baths, fixtures, and units.

Table with columns: ELEMENT, CD, DESCRIPTION, ADJ. Lists building elements like FOUNDATION, EXT. COVER, ROOF SHAPE, ROOF COVER, FLOOR COVER, INT. FINISH, HEATING/COOL, FUEL SOURCE.

Table with columns: S, BAT, T, DESCRIPTION, UNITS, YB, ADJ PRICE, RCN. Lists building systems and materials like BMU, BAS, BMF, USF, L, C, WDK, OPA, K, PTA, L, F11, GFP.

Summary table with columns: TOTAL RCN, CONDITION ELEM, CD, EFF. YR/AGE, COND, FUNC, ECON, DEPR, RCNLD. Includes totals for RCN, condition elements, and depreciation.

DETAILED

BUILDING

UNIT

NO

Key: 3444

Town of CHATHAM - Fiscal Year 2024

9/7/2023 9:38 am SEQ #: 3.738

LEGALS

CURRENT OWNER		PARCEL ID	LOCATION		
SHELLIE S LOVALLO TRUST 2012 LOVALLO SHELLIE S TRUSTEE 41 HOMER RD BELMONT, MA 02478		15H-70-EA1	193 EMERY LN		
TRANSFER HISTORY		DOS	T	SALE PRICE	BK-PG (Cert)

CLASS	CLASS%	DESCRIPTION			BN ID	BN	CARD	
1090	100	MULTIPLE HSES				2	2 of 2	
PMT NO	PMT DT	TY	DESC	AMOUNT	INSP	BY	1st	%

LAND

CD	T	AC/SF/UN	Nbhd	Inf1	Inf2	ADJ BASE	SAF	Inf3	Lpi	VC	CREDIT AMT	ADJ VALUE
----	---	----------	------	------	------	----------	-----	------	-----	----	------------	-----------

TOTAL	ZONING	FRNT	ASSESSED	CURRENT	PREVIOUS
Nbhd	NOTE		LAND	463,500	
Inf1		BUILDING			
Inf2		DETACHED			
			OTHER		
			TOTAL		

DETACHED

TY	QUAL	COND	DIM/NOTE	YB	UNITS	ADJ PRICE	RCNLD
----	------	------	----------	----	-------	-----------	-------

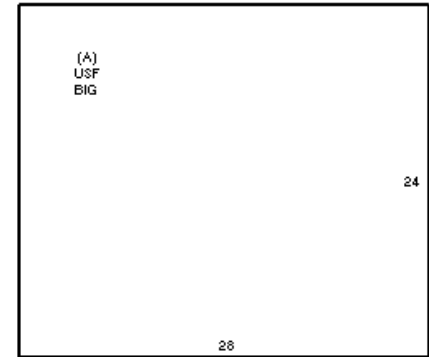

BUILDING

BUILDING	CD	ADJ	DESC	MEASURE	REVIEW	4/22/2015	TD
MODEL	1		RESIDENTIAL	LIST			
STYLE	17	0.95	GAR/APT [100%]				
QUALITY	V	2.35	VERY GOOD [100%]				
FRAME	1	1.00	WOOD FRAME [100%]				

BLDG COMMENTS
GUEST APT PER MLS

G

YEAR BLT	2010	SIZE ADJ	1.000	ELEMENT	CD	DESCRIPTION	ADJ	S	BAT	T	DESCRIPTION	UNITS	YB	ADJ PRICE	RCN	TOTAL RCN	526,748		
NET AREA	672	DETAIL ADJ	0.902	FOUNDATION	2	SLAB	0.95	A	BIG	N	BUILT-IN GARAGE	672		178.69	120,080	CONDITION ELEM	CD		
\$NLA(RCN)	\$784	OVERALL	1.000	EXT. COVER	1	WOOD SHINGLE	1.00	A	USF	L	UP-STRY FIN	672	2010	592.42	398,109	EXTERIOR			
				ROOF SHAPE	3	GAMBREL	1.00		ODS	O	OUT DOOR SHWR-A	1		3,471.00	3,471	INTERIOR			
				ROOF COVER	1	ASPH/CMP SHIN	1.00									KITCHEN			
				FLOOR COVER	1	HARDWOOD	1.00									BATHS			
				INT. FINISH	2	DRYWALL	1.00									HEAT			
				HEATING/COOL	1	FORCED AIR	1.00									ELECT			
				FUEL SOURCE	2	GAS	1.00												
																		EFF.YR/AGE	2010 / 12
																		COND	12 12 %
																		FUNC	0
																		ECON	0
																		DEPR	12 % GD 88
																		RCNLD	\$463,500