

Key: 3635

Town of CHATHAM - Fiscal Year 2024

9/7/2023 9:38 am SEQ #: 3.946

LEGAL

CURRENT OWNER				PARCEL ID				LOCATION			
NANCY N NEWTON REVOCABLE TRUST NEWTON NANCY N & JOHN B TRSTES 157 WOODVILLE RD WARREN, CT 06777-1203				16B-29-70				29 SILVER LEAF AVE			
TRANSFER HISTORY				DOS	T	SALE PRICE	BK-PG (Cert)				
NANCY N NEWTON REVOCABLE				01/10/2019	A	10	31774-37				
NEWTON JOHN B & NANCY N				11/19/1990	QS	255,000	7357-176				

CLASS	CLASS%	DESCRIPTION			BN ID	BN	CARD	
1010	100	SINGLE FAMILY				1	1 of 2	
PMT NO	PMT DT	TY	DESC	AMOUNT	INSP	BY	1st	%
06-017	02/06/2007	50	Meas & List			RRC	100	100
1990134	01/17/2006	3	Renovations	300,000	02/06/2007		100	100
	08/23/1990	99	n/a				100	100

LAND

CD	T	AC/SF/UN	Nbhd	Inf1	Inf2	ADJ BASE	SAF	Inf3	Lpi	VC	CREDIT AMT	ADJ VALUE	
100	S	16,534	CH	1.00	100	1.00	100	1.00	2,565,500	2.09	100	1.00	2,030,820

TOTAL	16,534 SF	ZONING	R40	FRNT	0	ASSESSED	CURRENT	PREVIOUS
Nbhd	CHATHAM	N O T E	Dist Ocn Wv			LAND	2,030,800	1,692,300
Inf1	100		LAND	773,100	681,600			
Inf2	100		OTHER	0	0			
			OTHER	112,700	103,800			
		TOTAL	2,916,600	2,477,700				

DETACHED

TY	QUAL	COND	DIM/NOTE	YB	UNITS	ADJ PRICE	RCNLD

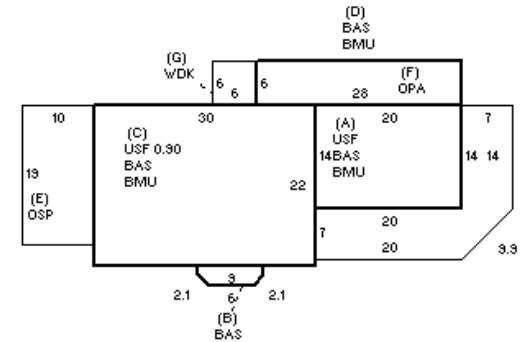

BUILDING

BUILDING	CD	ADJ	DESC	MEASURE	2/21/2017	MR
MODEL	1		RESIDENTIAL	LIST	2/21/2017	EST
STYLE	18	1.30	RENO'D ANTIQUE [100%]	REVIEW	4/26/2021	APK
QUALITY	+	1.20	PLUS AVE [100%]			
FRAME	1	1.00	WOOD FRAME [100%]			

BLDG COMMENTS  
COMPLETE RENO 2006 (PERMIT)

LOADING

YEAR BLT	1830	SIZE ADJ	1.000	ELEMENT	CD	DESCRIPTION	ADJ	S	BAT	T	DESCRIPTION	UNITS	YB	ADJ PRICE	RCN	TOTAL RCN	920,314		
NET AREA	2,002	DETAIL ADJ	1.352	FOUNDATION	4	FLR & WALL	1.00	+	BMU	N	BSMT UNFINISHED	1,108		84.94	94,114	CONDITION ELEM	CD		
\$NLA(RCN)	\$460	OVERALL	1.000	EXT. COVER	1	WOOD SHINGLE	1.00	+	USF	L	UP-STRY FIN	874	1830	336.78	294,343	EXTERIOR	V		
				ROOF SHAPE	1	GABLE	1.00	+	BAS	L	BAS AREA	1,128	1830	396.89	447,697	INTERIOR	G		
				ROOF COVER	2	WOOD SHIN	1.01	E	OSP	N	OPEN SCR PORCH	190		94.56	17,966	KITCHEN	G		
				FLOOR COVER	2	SOFTWOOD	1.00	F	OPA	N	OPEN PORCH	263		91.32	24,017	BATHS	G		
				INT. FINISH	1	PLASTER	1.00	G	WDK	N	WOOD DECK	36		70.07	2,522	HEAT	U		
				HEATING/COOL	9	WARM/COOL AIR	1.03	F21	O	FPL 2S 1OP	2		12,451.20	24,902	ELECT	U			
				FUEL SOURCE	2	GAS	1.00	ODS	O	OUT DOOR SHWR-A	1		1,772.40	1,772					
																		EFF.YR/AGE	2006 / 16
																		COND	16 16%
																		FUNC	0
																		ECON	0
																		DEPR	16 % GD 84
																		RCNLD	\$773,100

Key: 3635

Town of CHATHAM - Fiscal Year 2024

9/7/2023 9:38 am SEQ #: 3.947

LEGAL

CURRENT OWNER				PARCEL ID				LOCATION			
NANCY N NEWTON REVOCABLE TRUST NEWTON NANCY N & JOHN B TRSTES 157 WOODVILLE RD WARREN, CT 06777-1203				16B-29-70				29 SILVER LEAF AVE			
TRANSFER HISTORY				DOS	T	SALE PRICE	BK-PG (Cert)				

CLASS	CLASS%	DESCRIPTION				BN ID	BN	CARD	
1010	100	SINGLE FAMILY					2	2 of 2	
PMT NO	PMT DT	TY	DESC	AMOUNT	INSP	BY	1st	%	

LAND

CD	T	AC/SF/UN	Nbhd	Inf1	Inf2	ADJ BASE	SAF	Inf3	Lpi	VC	CREDIT AMT	ADJ VALUE

TOTAL	ZONING	FRNT	ASSESSED	CURRENT	PREVIOUS
Nbhd	NOTE		LAND	112,700	
Inf1		BUILDING			
Inf2		DETACHED			
			OTHER		
			TOTAL		

DETACHED

TY	QUAL	COND	DIM/NOTE	YB	UNITS	ADJ PRICE	RCNLD

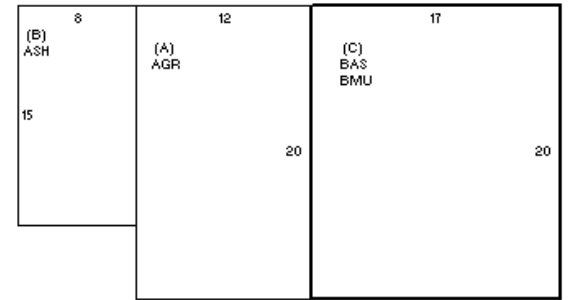

BUILDING

BUILDING	CD	ADJ	DESC	MEASURE	2/21/2017	MR
MODEL	1		RESIDENTIAL	LIST	2/21/2017	EST
STYLE	15	0.80	STUDIO [100%]	REVIEW	4/26/2021	APK
QUALITY	A	1.00	AVERAGE [100%]			
FRAME	1	1.00	WOOD FRAME [100%]			

BLDG COMMENTS
OFFICE

YEAR BLT	2006	SIZE ADJ	1.000
NET AREA	340	DETAIL ADJ	0.613
\$NLA(RCN)	\$395	OVERALL	1.000
CAPACITY		UNITS	ADJ
STORIES	1	1.00	
ROOMS	2	1.00	
BEDROOMS	0	1.00	
FULL BATHS	1	1.00	
1/2 BATHS	0	1.00	
FIXTURES	3	\$1,471	
UNITS	1	1.00	

ELEMENT	CD	DESCRIPTION	ADJ
FOUNDATION	4	FLR & WALL	1.00
EXT. COVER	1	WOOD SHINGLE	1.00
ROOF SHAPE	1	GABLE	1.00
ROOF COVER	2	WOOD SHIN	1.01
FLOOR COVER	8	MINIMUM	1.00
INT. FINISH	6	MINIMUM	0.95
HEATING/COOL	13	NONE	0.80
FUEL SOURCE	8	NONE	1.00

S	BAT	T	DESCRIPTION	UNITS	YB	ADJ PRICE	RCN
A	AGR	N	ATTACHED GARAGE	240		87.70	21,047
B	ASH	N	ATT SHED	120		60.60	7,272
C	BMU	N	BSMT UNFINISHED	340		90.48	30,763
C	BAS	L	BAS AREA	340	2006	216.44	73,589

TOTAL RCN	134,142
CONDITION ELEM	CD
EXTERIOR	A
INTERIOR	A
KITCHEN	A
BATHS	A
HEAT	A
ELECT	A
EFF.YR/AGE	2006 / 16
COND	16 16 %
FUNC	0
ECON	0
DEPR	16 % GD 84
RCNLD	\$112,700