

Key: 372

Town of CHATHAM - Fiscal Year 2024

9/7/2023 9:38 am SEQ #: 428

LEGAL

Table with columns: CURRENT OWNER, PARCEL ID, LOCATION, TRANSFER HISTORY, DOS, T, SALE PRICE, BK-PG (Cert)

Table with columns: CLASS, CLASS%, DESCRIPTION, BN ID, BN, CARD, PMT NO, PMT DT, TY, DESC, AMOUNT, INSP, BY, 1st, %

LAND

Table with columns: CD, T, AC/SF/UN, Nbhd, Inf1, Inf2, ADJ BASE, SAF, Inf3, Lpi, VC, CREDIT AMT, ADJ VALUE

Table with columns: TOTAL, 1.989 Acres, ZONING, R60, FRNT, 0, ASSESSED, CURRENT, PREVIOUS

DETACHED

Table with columns: TY, QUAL, COND, DIM/NOTE, YB, UNITS, ADJ PRICE, RCNLD

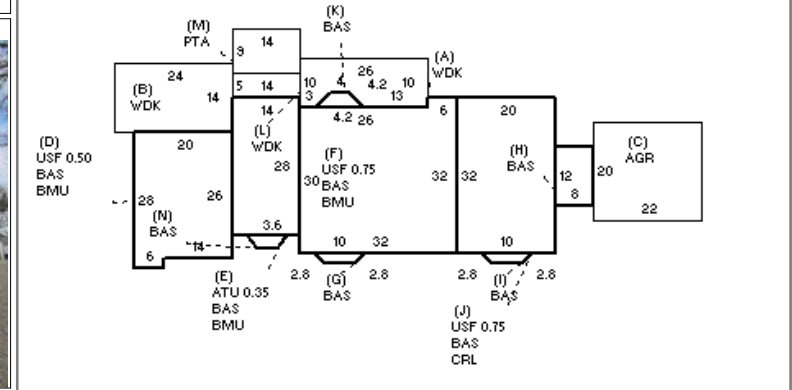

Table with columns: BLDG COMMENTS, APT (LEFT SIDE)=KIT, LIVRM, BDRM, BDRM, BTH

BU I L D I N G

Table with columns: BUILDING, CD, ADJ, DESC, MEASURE, 1/21/2020, NF, LIST, 1/21/2020, NF, REVIEW, 6/30/2021, EMZ

Large table with columns: YEAR BLT, SIZE ADJ, 1.000, ELEMENT, CD, DESCRIPTION, ADJ, S, BAT, T, DESCRIPTION, UNITS, YB, ADJ PRICE, RCN, TOTAL RCN, 1,339,890, CONDITION ELEM, CD, EFF. YR/AGE, 2003 / 19, COND, 19 19%, FUNC, 0, ECON, 0, DEPR, 19 % GD, 81, RCNLD, \$1,085,300