

Key: 3751

Town of CHATHAM - Fiscal Year 2024

9/7/2023 9:38 am SEQ #: 4.088

LEGAL

LAND

DETACHED

BUILDING

CURRENT OWNER				PARCEL ID				LOCATION			
THOMPSON REALTY TRUST THOMPSON RICHARD S TRUSTEE 8037 SE WOOD LAKE LN HOBE SOUND, FL 33455-8128				16C-50-C2				32 SUNSET LN			
TRANSFER HISTORY				DOS	T	SALE PRICE	BK-PG (Cert)				
THOMPSON REALTY TRUST				11/10/1998	A	1	11831-257				
THOMPSON				09/15/1965	QS	11,000	1314-907				

CLASS	CLASS%	DESCRIPTION			BN ID	BN	CARD	
1010	100	SINGLE FAMILY				1	1 of 1	
PMT NO	PMT DT	TY	DESC	AMOUNT	INSP	BY	1st	%
03-544	04/02/2004	50	Meas & List			RRC	100	100
P2003544	10/28/2003	2	Additions	19,000			100	100
03-323	10/19/2003	2	Additions	9,360			100	100
P2003323	07/16/2003	14	DECK	5,800			100	100
	06/30/2003	14	DECK	7,500			100	100

CD	T	AC/SF/UN	Nbhd	Inf1	Inf2	ADJ BASE	SAF	Inf3	Lpi	VC	CREDIT AMT	ADJ VALUE
100	S	13,503	CH	1.00	100	1.00	100	1.00	R10	3.75		1,055,460

TOTAL	13,503 SF	ZONING	R20	FRNT	132	ASSESSED	CURRENT	PREVIOUS
Nbhd	CHATHAM	NOTE Marsh View	LAND	1,055,500	879,500			
Inf1	100		BUILDING	233,500	212,300			
Inf2	100		DETACHED	900	800			
			OTHER	0	0			
TOTAL				1,289,900	1,092,600			

TY	QUAL	COND	DIM/NOTE	YB	UNITS	ADJ PRICE	RCNLD
SHF	A	1.00	30 0.70 8X10		80	15.24	900

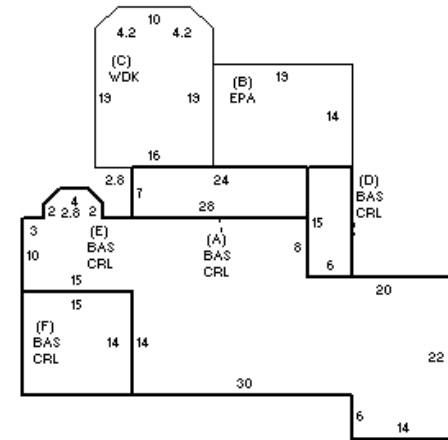

BUILDING	CD	ADJ	DESC	MEASURE	1/31/2017	MR
MODEL	1		RESIDENTIAL	LIST	1/31/2017	EST
STYLE	1	0.85	RANCH [100%]	REVIEW	3/3/2017	MR
QUALITY	-	0.80	MINUS AVE [100%]			
FRAME	1	1.00	WOOD FRAME [100%]			

YEAR BLT	1950	SIZE ADJ	1.000	ELEMENT	CD	DESCRIPTION	ADJ	S	BAT	T	DESCRIPTION	UNITS	YB	ADJ PRICE	RCN	TOTAL RCN	359,156
NET AREA	1,626	DETAIL ADJ	0.850	FOUNDATION	4	FLR & WALL	1.00	+	CRL	N	CRAWL SPACE	1,626		15.70	25,526	CONDITION ELEM	CD
\$NLA(RCN)	\$221	OVERALL	1.000	EXT. COVER	1	WOOD SHINGLE	1.00	A	BAS	L	BAS AREA	168	1955	173.04	29,070	EXTERIOR	A
				ROOF SHAPE	1	GABLE	1.00	B	EPA	N	ENCL PORCH	266		106.96	28,451	INTERIOR	A
				ROOF COVER	1	ASPH/CMP SHIN	1.00	C	WDK	N	WOOD DECK	343		46.72	16,025	KITCHEN	A
				FLOOR COVER	1	HARDWOOD	1.00	D	BAS	L	BAS AREA	90	2002	173.04	15,574	BATHS	A
				INT. FINISH	2	DRYWALL	1.00	E	BAS	L	BAS AREA	1,158	1950	173.04	200,380	HEAT	A
				HEATING/COOL	1	FORCED AIR	1.00	F	BAS	L	BAS AREA	210	1967	173.04	36,338	ELECT	A
				FUEL SOURCE	2	GAS	1.00	GFP	O		GAS LOG/FP/E FP	1		4,977.60	4,978		
								ODS	O		OUT DOOR SHWR-A	1		1,181.60	1,182		
																EFF.YR/AGE	1969 / 53
																COND	35 35%
																FUNC	0
																ECON	0
																DEPR	35 % GD 65
																RCNLD	\$233,500