

Key: 3854

Town of CHATHAM - Fiscal Year 2024

9/7/2023 9:38 am SEQ #: 4.210

LEGAL

LAND

DETACHED

BUILDING

| CURRENT OWNER | | PARCEL ID | | LOCATION | | | | | | | | |
|--|---|------------|------|----------------|--------------|-----------|------|------|------|-----|------------|-----------|
| CAMPBELL DANIEL & JENNIFER 1211 INDIAN MOUND TR VERO BEACH, FL 32963 | | 16D-46-13 | | 38 WILLOW BEND | | | | | | | | |
| TRANSFER HISTORY | | DOS | T | SALE PRICE | BK-PG (Cert) | | | | | | | |
| CAMPBELL DANIEL & JENNIFE | | 10/05/2018 | QS | 1,195,000 | 31579-166 | | | | | | | |
| PLOTKIN MARK E & TERESA C | | 11/04/2005 | QS | 940,000 | 20441-325 | | | | | | | |
| FITZGERALD WILLIAM & PATR | | 02/10/2005 | A | 1 | 19518-225 | | | | | | | |
| CD | T | AC/SF/UN | Nbhd | Inf1 | Inf2 | ADJ BASE | SAF | Inf3 | Lpi | VC | CREDIT AMT | ADJ VALUE |
| 100 | S | 5,662 | CH | 1.00 | 1.00 | 1,466,000 | 5.23 | 1.00 | 1.00 | R03 | 4.00 | 996,840 |

| CLASS | CLASS% | DESCRIPTION | | BN ID | BN | CARD | |
|----------|------------|---------------|--------------|---------|------------|--------|---------|
| 1010 | 100 | SINGLE FAMILY | | | 1 | 1 of 1 | |
| PMT NO | PMT DT | TY | DESC | AMOUNT | INSP | BY | 1st % |
| 21-1010 | 11/03/2021 | 3 | Renovations | 225,000 | 02/22/2023 | NF | 100 100 |
| 21-171 | 03/04/2021 | 10 | Reroof | 31,554 | 03/31/2022 | NF | 100 100 |
| | 11/01/2018 | 98 | SALES QUESTI | | | | 100 100 |
| | 02/08/2006 | 50 | Meas & List | | | JB | 100 100 |
| P2003050 | 02/03/2003 | 3 | Renovations | 6,000 | | | 100 100 |

| TOTAL | 5,662 SF | ZONING | R20 | FRNT | 0 | ASSESSED | CURRENT | PREVIOUS |
|-------|----------|--------|--------------|------------------|------------------|----------|---------|----------|
| Nbhd | CHATHAM | NOTE | LAND | 996,800 | 830,700 | | | |
| Inf1 | 100 | | BUILDING | 789,900 | 559,200 | | | |
| Inf2 | 100 | | DETACHED | 0 | 0 | | | |
| | | | OTHER | 0 | 0 | | | |
| | | | TOTAL | 1,786,700 | 1,389,900 | | | |

| TY | QUAL | COND | DIM/NOTE | YB | UNITS | ADJ PRICE | RCNLD |
|----|------|------|----------|----|-------|-----------|-------|
| | | | | | | | |

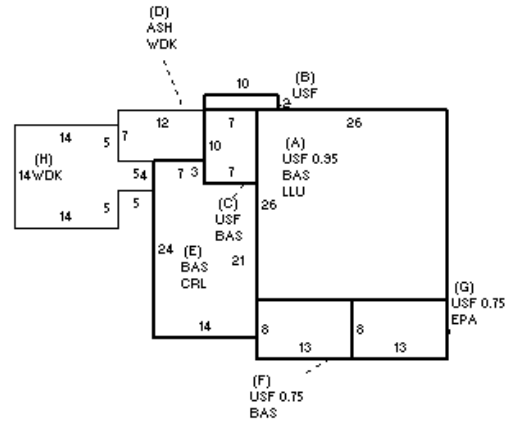

| BUILDING | CD | ADJ | DESC | MEASURE | 3/31/2022 | NF |
|----------|----|------|-----------------------|---------|-----------|-----|
| MODEL | 1 | | RESIDENTIAL | LIST | 3/31/2022 | EST |
| STYLE | 18 | 1.30 | RENO'D ANTIQUE [100%] | REVIEW | 3/16/2023 | EMZ |
| QUALITY | + | 1.20 | PLUS AVE [100%] | | | |
| FRAME | 1 | 1.00 | WOOD FRAME [100%] | | | |

BLDG COMMENTS
INFO @ DOOR (3/31/22)

| YEAR BLT | 1930 | SIZE ADJ | 1.000 | ELEMENT | CD | DESCRIPTION | ADJ | S | BAT | T | DESCRIPTION | UNITS | YB | ADJ PRICE | RCN | TOTAL RCN | 940,404 | |
|------------|-------|------------|-------|--------------|----|---------------|------|---|-----|-----|----------------|-----------------|------|-----------|----------|----------------|------------|--|
| NET AREA | 2,053 | DETAIL ADJ | 1.339 | FOUNDATION | 4 | FLR & WALL | 1.00 | A | LLU | N | LOWER LEVEL UN | 676 | | 211.20 | 142,772 | CONDITION ELEM | CD | |
| \$NLA(RCN) | \$458 | OVERALL | 1.000 | EXT. COVER | 2 | CLAPBOARD | 1.00 | + | USF | L | UP-STRY FIN | 888 | 1930 | 318.07 | 282,443 | EXTERIOR | G | |
| | | | | ROOF SHAPE | 1 | GABLE | 1.00 | + | BAS | L | BAS AREA | 1,165 | 1930 | 374.84 | 436,691 | INTERIOR | G | |
| | | | | ROOF COVER | 1 | ASPH/CMP SHIN | 1.00 | + | WDK | N | WOOD DECK | 300 | | 70.08 | 21,024 | KITCHEN | V | |
| | | | | FLOOR COVER | 23 | SOFTWD/CARPET | 1.00 | D | ASH | N | ATT SHED | 84 | | 72.71 | 6,108 | BATHS | V | |
| | | | | INT. FINISH | 15 | PLASTR/OTHER | 1.00 | E | CRL | N | CRAWL SPACE | 315 | | 32.29 | 10,172 | HEAT | U | |
| | | | | HEATING/COOL | 9 | WARM/COOL AIR | 1.03 | G | EPA | N | ENCL PORCH | 104 | | 160.44 | 16,686 | ELECT | U | |
| | | | | FUEL SOURCE | 2 | GAS | 1.00 | | F21 | O | FPL 2S 1OP | 1 | | 12,451.20 | 12,451 | | | |
| | | | | | | | | | | ODS | O | OUT DOOR SHWR-A | 1 | | 1,772.40 | 1,772 | | |
| | | | | | | | | | | | | | | | | EFF.YR/AGE | 2006 / 16 | |
| | | | | | | | | | | | | | | | | COND | 16 16 % | |
| | | | | | | | | | | | | | | | | FUNC | 0 | |
| | | | | | | | | | | | | | | | | ECON | 0 | |
| | | | | | | | | | | | | | | | | DEPR | 16 % GD 84 | |
| | | | | | | | | | | | | | | | | RCNLD | \$789,900 | |