

Key: 3928

Town of CHATHAM - Fiscal Year 2024

9/7/2023 9:38 am SEQ #: 4.302

LEGAL

LAND

DETACHED

BUILDING

CURRENT OWNER				PARCEL ID				LOCATION			
GOODWIN THOMAS P & JUDITH E PO BOX 432 CHATHAM, MA 02633-0432				16F-2-S3				369 SHORE RD			
TRANSFER HISTORY				DOS	T	SALE PRICE	BK-PG (Cert)				
GOODWIN THOMAS P & JUDITH				01/12/2005	A	100	(175640)				
GOODWIN THOMAS				02/11/2004	A	100	(172086)				
GOODWIN, THOMAS TRUSTEE				04/03/1998	A	1	(147995)				

CLASS	CLASS%	DESCRIPTION			BN ID	BN	CARD	
1010	100	SINGLE FAMILY				1	1 of 1	
PMT NO	PMT DT	TY	DESC	AMOUNT	INSP	BY	1st	%
16-397	06/16/2016	3	Renovations		05/16/2017	NF	100	100
	05/11/2016	2	Additions		05/11/2016	APK	100	100
15-232	05/05/2015	10	Reroof	7,450			100	100
	05/16/2008	50	Meas & List			RRC	100	100
1997081	05/02/1997	99	n/a				100	100

CD	T	AC/SF/UN	Nbhd	Inf1	Inf2	ADJ BASE	SAF	Inf3	Lpi	VC	CREDIT AMT	ADJ VALUE
100	S	34,810	CH	1.00	1.00	2,382,250	1.12	1.00	1.00	R12	6.50	2,131,790

TOTAL	34,810 SF	ZONING	R40	FRNT	0	ASSESSED	CURRENT	PREVIOUS
Nbhd	CHATHAM	NOTE SI Ocn Wv	LAND		2,131,800	1,776,400		
Inf1	100		BUILDING		523,500	476,400		
Inf2	100		DETACHED		0	0		
			OTHER		0	0		
TOTAL				2,655,300		2,252,800		

TY	QUAL	COND	DIM/NOTE	YB	UNITS	ADJ PRICE	RCNLD	PHOTO	02/18/2022
									

BUILDING	CD	ADJ	DESC	MEASURE	2/18/2022	NF
MODEL	1		RESIDENTIAL	LIST	2/18/2022	EST
STYLE	1	0.85	RANCH [100%]	REVIEW	2/25/2022	EMZ
QUALITY	+	1.20	PLUS AVE [100%]			
FRAME	1	1.00	WOOD FRAME [100%]			

YEAR BLT	1953	SIZE ADJ	1.000	ELEMENT	CD	DESCRIPTION	ADJ	S	BAT	T	DESCRIPTION	UNITS	YB	ADJ PRICE	RCN	TOTAL RCN	688,764
NET AREA	1,584	DETAIL ADJ	0.875	FOUNDATION	4	FLR & WALL	1.00	A	BMU	N	BSMT UNFINISHED	627		98.80	61,950	CONDITION ELEM	CD
\$NLA(RCN)	\$435	OVERALL	1.000	EXT. COVER	1	WOOD SHINGLE	1.00	A	BMF	N	BSMT FINISH-SEP	941		130.32	122,632	EXTERIOR	A
				ROOF SHAPE	1	GABLE	1.00	B	OPA	N	OPEN PORCH	112		91.32	10,228	INTERIOR	G
				ROOF COVER	1	ASPH/CMP SHIN	1.00	C	AGR	N	ATTACHED GARAGE	483		94.38	45,584	KITCHEN	V
				FLOOR COVER	1	HARDWOOD	1.00	D	PTA	N	PATIO/STOOP	240		21.48	5,155	BATHS	G
				INT. FINISH	2	DRYWALL	1.00	+	BAS	L	BAS AREA	1,584	1953	268.78	425,750	HEAT	A
				HEATING/COOL	9	WARM/COOL AIR	1.03	F11	O	FPL 1S 1OP	1		8,972.40	8,972	ELECT	U	
				FUEL SOURCE	2	GAS	1.00	ODS	O	OUT DOOR SHWR-A	1		1,772.40	1,772			
																EFF.YR/AGE	1991 / 31
																COND	24 24 %
																FUNC	0
																ECON	0
																DEPR	24 % GD 76
																RCNLD	\$523,500

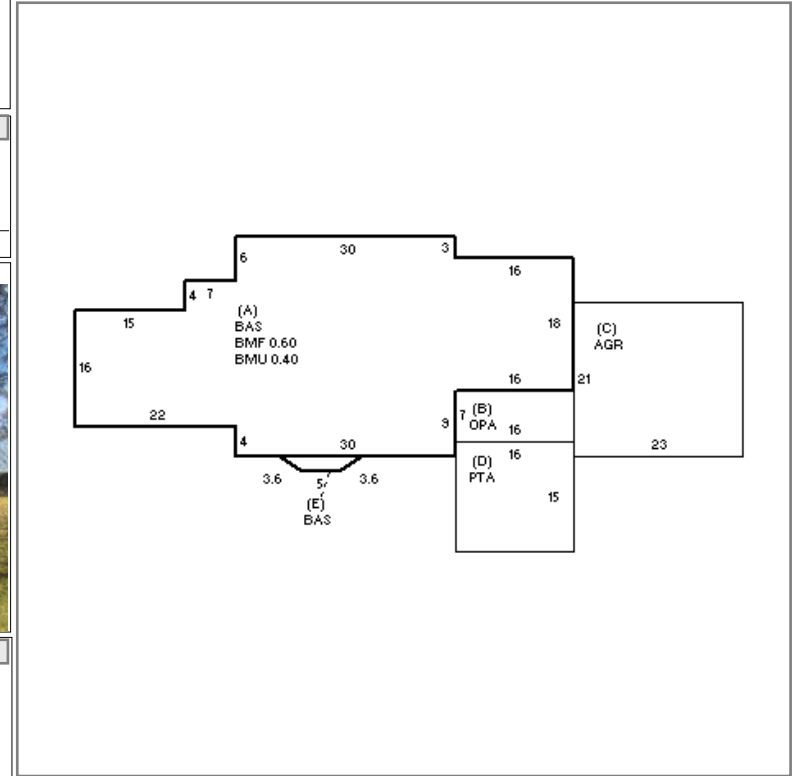

BLDG COMMENTS	BLDG COMMENTS
BLM=2BDRMS,1RM	