

Key: 3933

Town of CHATHAM - Fiscal Year 2024

9/7/2023 9:38 am SEQ #: 4.307

LEGAL

LAND

DETACHED

BUILDING

CURRENT OWNER				PARCEL ID				LOCATION			
CBI OWNER LLC CAPITAL PROPERTIES 31 ST JAMES AVE BOSTON, MA 02116				16F-24A-E6				366 SHORE RD			
TRANSFER HISTORY				DOS	T	SALE PRICE	BK-PG (Cert)				
CBI OWNER LLC				06/24/2011	B	10	25527-1				
CBI PC LLC & CBI NCA LLC				06/03/2006	J	119,000,000	(180230)				
CBI NCA LLC, ATTN: RICHA				06/02/2006	J	42,804,300	21064-60				

CLASS	CLASS%	DESCRIPTION			BN ID	BN	CARD	
3000	100	HOTELS				1	1 of 1	
PMT NO	PMT DT	TY	DESC	AMOUNT	INSP	BY	1st	%
21-066	10/14/2021	75	SPECIAL PERM					0
	02/03/2002	50	Meas & List			JB	100	100
P2001271	12/28/2001	99	n/a				100	100
01-631	12/28/2001	1	New Construc	858,650			100	100
01-602	12/11/2001	5	Demolitions	20,000			100	100

CD	T	AC/SF/UN	Nbhd	Inf1	Inf2	ADJ BASE	SAF	Inf3	Lpi	VC	CREDIT AMT	ADJ VALUE
103	S	22,178	CI	1.00	100	1.00	100	1.00	1.00	CBI	6.50	2,177,830

TOTAL	22,178 SF	ZONING	R40	FRNT	0	ASSESSED	CURRENT	PREVIOUS
Nbhd	COMMERCIAL	NOTE No Revetment w/a	LAND	2,177,800	1,979,900			
Inf1	100		BUILDING	1,064,800	971,200			
Inf2	100		DETACHED	3,400	3,300			
			OTHER	0	0			
TOTAL			3,246,000	2,954,400				

TY	QUAL	COND	DIM/NOTE	YB	UNITS	ADJ PRICE	RCNLD
LH1	A	1.00	50 0.50		3	2,291.80	3,400



BLDG COMMENTS
366 MOONCUSSER COTTAGE-3 SUITES & 3 GUEST RMS

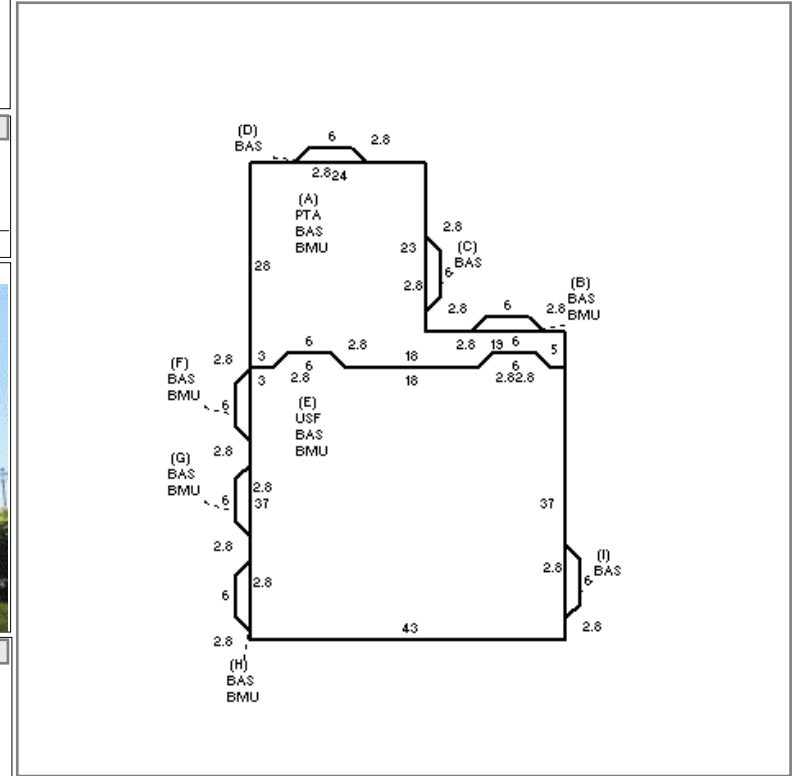

BUILDING	CD	ADJ	DESC	MEASURE		
MODEL	5		CIM	LIST		
STYLE	44	2.20	B&B/INN [100%]	REVIEW	11/16/2012	DF
QUALITY	V	1.60	VERY GOOD [100%]			
FRAME	1	1.00	WOOD FRAME [100%]			

YEAR BLT	2002	SIZE ADJ	1.000	ELEMENT	CD	DESCRIPTION	ADJ	S	BAT	T	DESCRIPTION	UNITS	YB	ADJ PRICE	RCN	TOTAL RCN	1,298,532		
NET AREA	4,093	DETAIL ADJ	2.215	FOUNDATION	4	FLR & WALL	1.00	+	BMU	N	BSMT UNF	2,422		28.30	68,543	CONDITION ELEM CD			
\$NLA(RCN)	\$317	OVERALL	1.000	EXT. COVER	1	WOOD SHINGLE	1.00	A	PTA	N	PATIO	735		10.08	7,409	EXTERIOR			
CAPACITY			UNITS	ADJ	ROOF SHAPE	1	GABLE	1.00	+	BAS	L	BASE AREA	2,470	2002	292.39	722,196	INTERIOR		
STORIES	2	1.00	ROOF COVER	2	WOOD SHINGLE	1.01	E	USF	L	UP-STRY FIN	1,623	2002	292.39	474,544	CDN/APP				
% HEATED	100	1.00	FLOOR COVER	1	HARDWOOD	1.00		SPD	N	SPRKNK-DRY	4,093		1.70	6,958					
% AIR COND	100	1.03	INT. FINISH	2	DRYWALL	1.00		F22	O	FPL 2S 2OP	2		7,518.50	15,037					
% SPRINKLER	100	1.00	HEATING/COOL	11	HOT WT/COOL AIR	1.02		GFP	O	GAS LOG/FP/E FP	1		3,845.00	3,845					
			FUEL SOURCE	2	GAS	1.00													
																EFF.YR/AGE	2004 / 18		
																COND	18 18 %		
																FUNC	0		
																ECON	0		
																DEPR	18	% GD	82
																RCNLD	\$1,064,800		