

Key: 3974

Town of CHATHAM - Fiscal Year 2024

9/7/2023 9:38 am SEQ #: 4.350

LEG  
AL  
LAND

CURRENT OWNER				PARCEL ID				LOCATION				
FLANAGAN WILLIAM J JR & BARBARA A PO BOX 1347 EASTVILLE, VA 23347-1347				16H-11-6				556 OLD HARBOR RD				
TRANSFER HISTORY				DOS	T	SALE PRICE	BK-PG (Cert)					
FLANAGAN WILLIAM J JR & B				07/25/2011	A	1,400,000	25582-107					
PARKER C WISEMAN FAMILY T				08/25/2003	A	1	17528-192					
WISEMAN REALTY TRUST				04/25/2002	A	1	15085-189					
CD	T	AC/SF/UN	Nbhd	Inf1	Inf2	ADJ BASE	SAF	Inf3	Lpi	VC	CREDIT AMT	ADJ VALUE
100	S	34,810	NC	1.00	1.00	2,199,000	1.12	100	1.00	OV3	6.00	1,967,800

CLASS	CLASS%	DESCRIPTION			BN ID	BN	CARD	
1010	100	SINGLE FAMILY				1	1 of 1	
PMT NO	PMT DT	TY	DESC	AMOUNT	INSP	BY	1st	%
12-282	07/22/2013	50	Meas & List			SF	100	100
12-282	06/01/2012	5	Demolitions	10,000	07/22/2013	SF	100	100
12-283	06/01/2012	1	New Construc	1,500,000	03/12/2014	MR	100	100
1998206	05/16/2008	50	Meas & List			RRC	100	100
	10/02/1998	99	n/a				100	100

TOTAL	34,810 SF	ZONING	R40	FRNT	0	ASSESSED	CURRENT	PREVIOUS
Nbhd	NORTH CHATHAM	N O T E	Ocn Wv			LAND	1,967,800	1,366,500
Inf1	100		BUILDING	4,041,400	3,373,200			
Inf2	100		DETACHED	0	0			
			OTHER	0	0			
<b>TOTAL</b>			<b>6,009,200</b>	<b>4,739,700</b>				

D  
E  
T  
A  
C  
H  
E  
D

TY	QUAL	COND	DIM/NOTE	YB	UNITS	ADJ PRICE	RCNLD

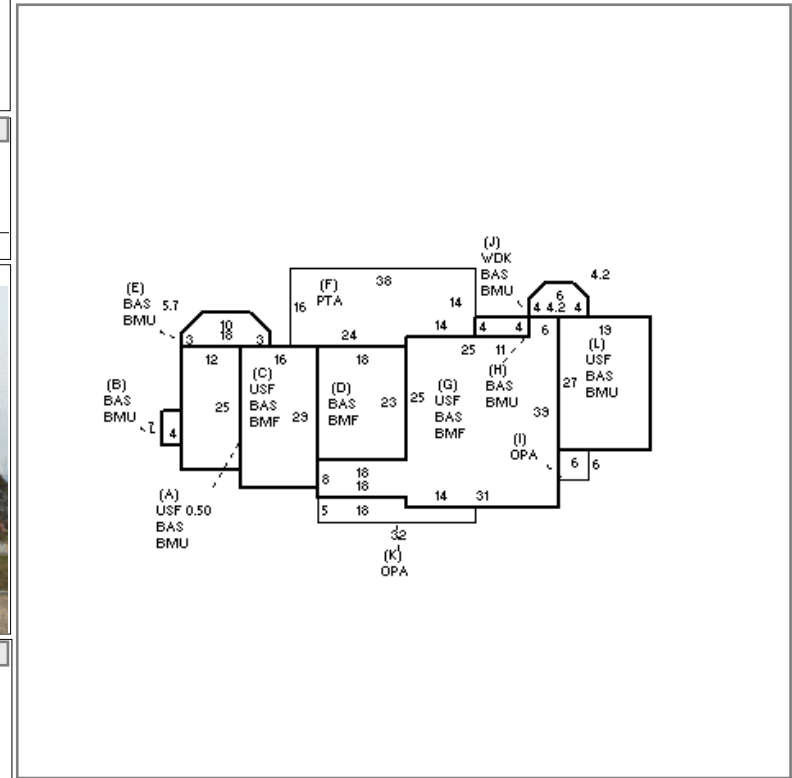
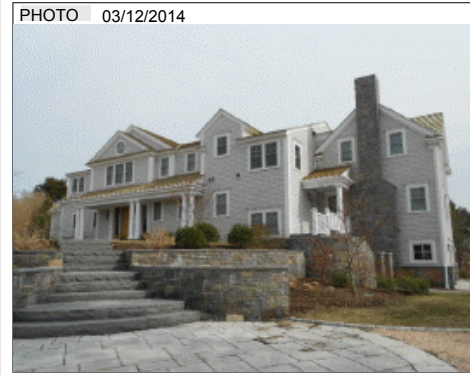

BLDG COMMENTS

B  
U  
I  
L  
D  
I  
N  
G

BUILDING	CD	ADJ	DESC	MEASURE	7/22/2013	SF
MODEL	1		RESIDENTIAL	LIST	7/22/2013	SF
STYLE	19	1.30	NEW STYLE [100%]	REVIEW	3/17/2014	DD
QUALITY	V	2.35	VERY GOOD [100%]			
FRAME	1	1.00	WOOD FRAME [100%]			

YEAR BLT	2012	SIZE ADJ	1.000	ELEMENT	CD	DESCRIPTION	ADJ	S	BAT	T	DESCRIPTION	UNITS	YB	ADJ PRICE	RCN	TOTAL RCN	4,490,425														
NET AREA	5,581	DETAIL ADJ	1.352	FOUNDATION	4	FLR & WALL	1.00	+	BMU	N	BSMT UNFINISHED	1,070		167.48	179,209																
\$NLA(RCN)	\$805	OVERALL	1.000	EXT. COVER	1	WOOD SHINGLE	1.00	+	BAS	L	BAS AREA	3,201	2012	689.91	2,208,403																
				ROOF SHAPE	1	GABLE	1.00	+	USF	L	UP-STRY FIN	2,380	2012	585.41	1,393,280																
				ROOF COVER	2	WOOD SHIN	1.01	+	BMF	N	BSMT FINISH-SEP	2,131		255.21	543,854																
				FLOOR COVER	1	HARDWOOD	1.00	F	PTA	N	PATIO/STOOP	580		42.07	24,398																
				INT. FINISH	2	DRYWALL	1.00	+	OPA	N	OPEN PORCH	168		178.84	30,045																
				HEATING/COOL	9	WARM/COOL AIR	1.03	J	WDK	N	WOOD DECK	75		137.24	10,293																
				FUEL SOURCE	2	GAS	1.00		BMG	O	BSMT GARAGE	2		6,508.35	13,017																
									F21	O	FPL 2S 1OP	1		24,383.60	24,384																
<table border="1"> <thead> <tr> <th>CONDITION ELEM</th> <th>CD</th> </tr> </thead> <tbody> <tr> <td>EXTERIOR</td> <td>A</td> </tr> <tr> <td>INTERIOR</td> <td>A</td> </tr> <tr> <td>KITCHEN</td> <td>A</td> </tr> <tr> <td>BATHS</td> <td>A</td> </tr> <tr> <td>HEAT</td> <td>A</td> </tr> <tr> <td>ELECT</td> <td>A</td> </tr> </tbody> </table>																	CONDITION ELEM	CD	EXTERIOR	A	INTERIOR	A	KITCHEN	A	BATHS	A	HEAT	A	ELECT	A	
CONDITION ELEM	CD																														
EXTERIOR	A																														
INTERIOR	A																														
KITCHEN	A																														
BATHS	A																														
HEAT	A																														
ELECT	A																														
<table border="1"> <thead> <tr> <th>EFF. YR/AGE</th> <th colspan="2">2012 / 10</th> </tr> </thead> <tbody> <tr> <td>COND</td> <td>10</td> <td>10 %</td> </tr> <tr> <td>FUNC</td> <td>0</td> <td></td> </tr> <tr> <td>ECON</td> <td>0</td> <td></td> </tr> <tr> <td>DEPR</td> <td>10</td> <td>% GD 90</td> </tr> </tbody> </table>																	EFF. YR/AGE	2012 / 10		COND	10	10 %	FUNC	0		ECON	0		DEPR	10	% GD 90
EFF. YR/AGE	2012 / 10																														
COND	10	10 %																													
FUNC	0																														
ECON	0																														
DEPR	10	% GD 90																													
RCNLD																\$4,041,400															