

Key: 416

Town of CHATHAM - Fiscal Year 2024

9/7/2023 9:38 am SEQ #: 475

LEGAL

LAND

DETACHED

BUILDING

CURRENT OWNER				PARCEL ID				LOCATION			
CUOZZI NICHOLAS P & DOLORES C 1031 ORLEANS RD N CHATHAM, MA 02650				10K-1A-16A2				1031 ORLEANS RD			
TRANSFER HISTORY				DOS	T	SALE PRICE	BK-PG (Cert)				
CUOZZI NICHOLAS P & DOLOR				06/07/2022	A	1	35173-56				
NICHOLAS P CUOZZI 2008 RE				06/12/2008	A	1	22975-272				
NICHOLAS & DOLORES 2008 R				01/12/1984	D	37,500	3984-223				

CLASS	CLASS%	DESCRIPTION			BN ID	BN	CARD	
1010	100	SINGLE FAMILY				1	1 of 1	
PMT NO	PMT DT	TY	DESC	AMOUNT	INSP	BY	1st	%
19-299	05/01/2019	3	Renovations	2,000	02/11/2020	TCK	100	100
13-132	03/14/2013	10	Reroof	9,500	04/16/2014	MR	100	100
	05/09/2007	50	Meas & List			RRC	100	100
00-399	08/01/2000	2	Additions	50,000			100	100
99-064	02/01/1999	4	Outbuildings	1,340			100	100

CD	T	AC/SF/UN	Nbhd	Inf1	Inf2	ADJ BASE	SAF	Inf3	Lpi	VC	CREDIT AMT	ADJ VALUE
100	S	35,840	MC	1.00	100	1.00	100	1.00	CV1	2.30		758,330

TOTAL	35,840 SF	ZONING	R60	FRNT	0	ASSESSED	CURRENT	PREVIOUS
Nbhd	MID CHATHAM	NOTE				LAND	758,300	631,900
Inf1	100		BUILDING	546,400	497,000			
Inf2	100		DETACHED	0	0			
			OTHER	0	0			
						TOTAL	1,304,700	1,128,900

TY	QUAL	COND	DIM/NOTE	YB	UNITS	ADJ PRICE	RCNLD



BLDG COMMENTS

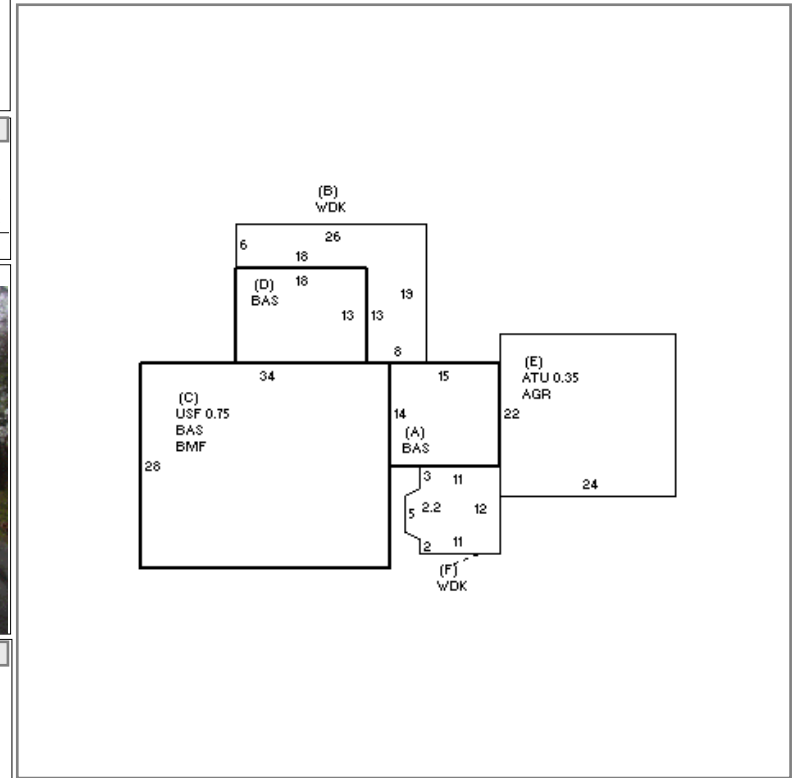

BUILDING	CD	ADJ	DESC	MEASURE
MODEL	1		RESIDENTIAL	
STYLE	4	1.00	CAPE [100%]	
QUALITY	A	1.00	AVERAGE [100%]	
FRAME	1	1.00	WOOD FRAME [100%]	

YEAR BLT	1984	SIZE ADJ	1.000	ELEMENT	CD	DESCRIPTION	ADJ
NET AREA	2,110	DETAIL ADJ	1.000	FOUNDATION	4	FLR & WALL	1.00
\$NLA(RCN)	\$324	OVERALL	1.000	EXT. COVER	1	WOOD SHINGLE	1.00
				ROOF SHAPE	1	GABLE	1.00
				ROOF COVER	1	ASPH/CMP SHIN	1.00
				FLOOR COVER	24	SOFTWD/ASPH TL	1.00
				INT. FINISH	2	DRYWALL	1.00
				HEATING/COOL	2	HOT WATER	1.00
				FUEL SOURCE	1	OIL	1.00

S	BAT	T	DESCRIPTION	UNITS	YB	ADJ PRICE	RCN
+	BAS	L	BAS AREA	1,396	1984	242.36	338,340
+	WDK	N	WOOD DECK	404		58.40	23,594
C	BMF	N	BSMT FINISH-SEP	952		108.60	103,387
C	USF	L	UP-STRY FIN	714	1984	205.65	146,837
E	AGR	N	ATTACHED GARAGE	528		77.87	41,113
E	ATU	N	UNFIN ATTIC	185		78.50	14,523
	F21	O	FPL 2S 1OP	1		10,376.00	10,376

TOTAL RCN	682,970
CONDITION ELEM	CD
EXTERIOR	A
INTERIOR	A
KITCHEN	G
BATHS	A
HEAT	A
ELECT	U
EFF.YR/AGE	2002 / 20
COND	20 20 %
FUNC	0
ECON	0
DEPR	20 % GD 80
RCNLD	\$546,400