

Key: 4353

Town of CHATHAM - Fiscal Year 2024

9/7/2023 9:38 am SEQ #: 4.769

LEG
A
L
L
A
N
D

CURRENT OWNER				PARCEL ID				LOCATION				
SCHANEY PAUL F & MEGHAN M 55 SNOWBERRY LN S CHATHAM, MA 02659				2B-105-R68				55 SNOWBERRY LN				
TRANSFER HISTORY				DOS	T	SALE PRICE	BK-PG (Cert)					
SCHANEY PAUL F & MEGHAN M				10/27/2016	QS	610,000	(211130)					
KEHOE JOHN P & ELIZABETH				06/22/2012	QS	526,000	(197466)					
JERZY ENGLE REV TRUST				10/26/1989	A	1	(118845)					
CD	T	AC/SF/UN	Nbhd	Inf1	Inf2	ADJ BASE	SAF	Inf3	Lpi	VC	CREDIT AMT	ADJ VALUE
100	S	17,405	SC	1.00	90	0.90	100	1.00		R07	1.75	460,550

CLASS	CLASS%	DESCRIPTION			BN ID	BN	CARD	
1010	100	SINGLE FAMILY				1	1 of 1	
PMT NO	PMT DT	TY	DESC	AMOUNT	INSP	BY	1st	%
21-1101	12/02/2021	77	SOLAR PANELS	90,000	03/18/2022	TCK	100	100
E20-425	12/31/2020	99	n/a				100	100
20-378	12/14/2020	13	SH.MTL/FHAIR	78,500	04/14/2021	NF	100	100
	01/30/2017	98	SALES QUESTI				100	100
	10/11/2016	3	Renovations		10/11/2016	APK	100	100

TOTAL	17,405 SF	ZONING	R20	FRNT	215	ASSESSED	CURRENT	PREVIOUS
Nbhd	SOUTH CHATHAM	N O T E	INFL = SEVERE TOPO			LAND	460,600	372,800
Inf1	90		BUILDING	847,200	770,800			
Inf2	100		DETACHED	0	0			
			OTHER	0	0			
						TOTAL	1,307,800	1,143,600

TY	QUAL	COND	DIM/NOTE	YB	UNITS	ADJ PRICE	RCNLD

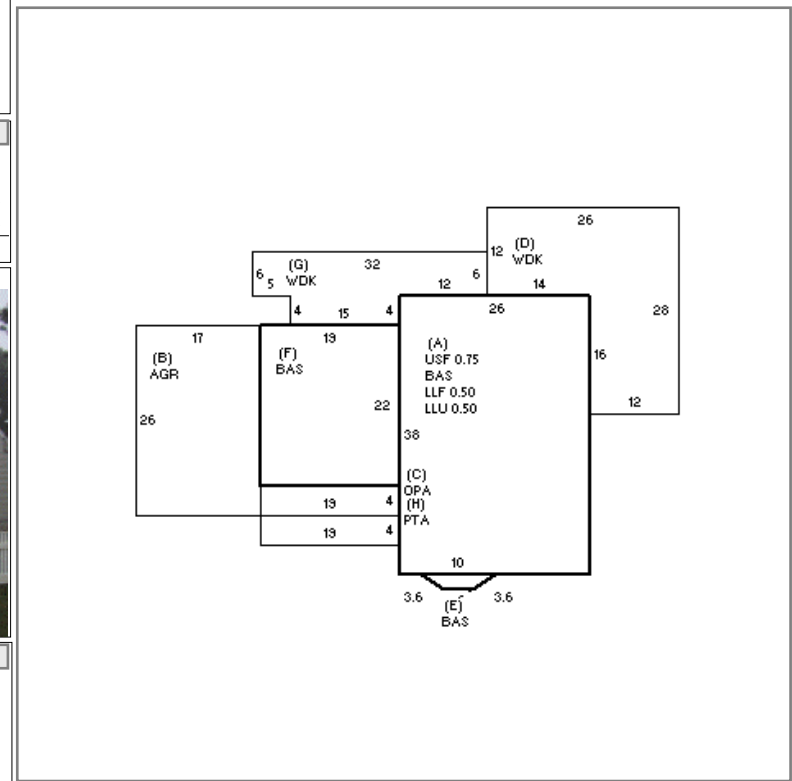

BUILDING	CD	ADJ	DESC	MEASURE	1/21/2022	TCK
MODEL	1		RESIDENTIAL	LIST	1/21/2022	EST
STYLE	4	1.00	CAPE [100%]	REVIEW	3/31/2022	EMZ
QUALITY	+	1.20	PLUS AVE [100%]			
FRAME	1	1.00	WOOD FRAME [100%]			

BLDG COMMENTS
LLF=FAM RM

D
E
T
A
C
H
E
D

B
U
I
L
D
I
N
G

YEAR BLT	1985	SIZE ADJ	1.000	ELEMENT	CD	DESCRIPTION	ADJ	S	BAT	T	DESCRIPTION	UNITS	YB	ADJ PRICE	RCN	TOTAL RCN	901,314	
NET AREA	2,161	DETAIL ADJ	1.050	FOUNDATION	4	FLR & WALL	1.00	A	LLU	N	LOWER LEVEL UN	494		162.57	80,311			
\$NLA(RCN)	\$417	OVERALL	1.000	EXT. COVER	2	CLAPBOARD	1.00	A	LLF	N	LOWER LEVEL FIN	494		212.34	104,897			
				ROOF SHAPE	1	GABLE	1.00	A	USF	L	UP-STRY FIN	741	1985	244.83	181,421			
				ROOF COVER	1	ASPH/CMP SHIN	1.00	B	AGR	N	ATTACHED GARAGE	442		95.32	42,131			
				FLOOR COVER	13	HARDWD/CARPET	1.00	C	OPA	N	OPEN PORCH	76		91.33	6,941			
				INT. FINISH	2	DRYWALL	1.00	+	WDK	N	WOOD DECK	756		70.08	52,980			
				HEATING/COOL	11	HT-WT/COOL AIR	1.05	+	BAS	L	BAS AREA	1,420	1985	288.54	409,722			
				FUEL SOURCE	1	OIL	1.00	H	PTA	N	PATIO/STOOP	76		21.47	1,632			
									F21	O	FPL 2S 1OP	1		12,451.20	12,451			
									GEN	O	GENERATOR	1		0.00				
									ODS	O	OUT DOOR SHWR-A	1		1,772.40	1,772			
																EFF.YR/AGE	2016 / 6	
																COND	6 6 %	
																FUNC	0	
																ECON	0	
																DEPR	6 % GD 94	
																RCNLD	\$847,200	