

Key: 447

Town of CHATHAM - Fiscal Year 2024

9/7/2023 9:38 am SEQ #: 508

LEGAL

LAND

CURRENT OWNER				PARCEL ID				LOCATION			
16 CAPTAIN COVE LLC 155 E BOARDWALK DR STE 473 FT COLLINS, CO 80525				10L-12-C4				16 CAPTAINS COVE LN			
TRANSFER HISTORY				DOS	T	SALE PRICE	BK-PG (Cert)				
16 CAPTAIN COVE LLC				09/10/2021	QS	2,599,000	34459-197				
GARAVEL JR GERALD & SHARO				09/16/2013	QS	1,675,500	27692-301				
PRESTIGE HOME BUILDING OF				06/18/2012	U	478,000	26422-93				

CLASS	CLASS%	DESCRIPTION			BN ID	BN	CARD	
1010	100	SINGLE FAMILY				1	1 of 1	
PMT NO	PMT DT	TY	DESC	AMOUNT	INSP	BY	1st	%
12-327	07/22/2013	51	Meas			SF	100	100
	07/06/2012	1	New Construc	510,000	04/14/2014	MR	100	100

CD	T	AC/SF/UN	Nbhd	Inf1	Inf2	ADJ BASE	SAF	Inf3	Lpi	VC	CREDIT AMT	ADJ VALUE
100	S	40,000	NC	1.00	70	0.70	100	1.00	100	CF4	5.20	1,225,030
300	A	0.156	NC	1.00	100	1.00	100	1.00	100	CF4	5.20	15,580

TOTAL	1.074 Acres		ZONING	R40	FRNT	0	ASSESSED	CURRENT	PREVIOUS
Nbhd	NORTH CHATHAM		N O T E	Letter from ComDev 8/30/01 Builable sig RYDERS COVE FRONT Inf1-Shape/Topo/Water Access			LAND	1,240,600	888,000
Inf1	70			BUILDING	1,789,900	1,541,800	DETACHED	0	0
Inf2	100			OTHER	0	0	TOTAL	3,030,500	2,429,800

DETACHED

TY	QUAL	COND	DIM/NOTE	YB	UNITS	ADJ PRICE	RCNLD

BLDG COMMENTS

LLF=1RM, 1FBATH

PHOTO 04/14/2014

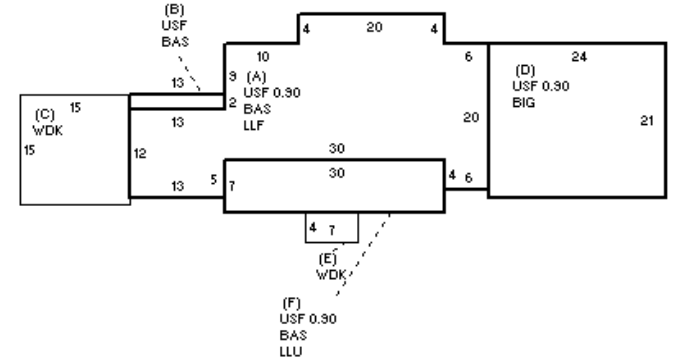

BUILDING

BUILDING	CD	ADJ	DESC	MEASURE	7/22/2013	SF
MODEL	1		RESIDENTIAL	LIST		
STYLE	4	1.00	CAPE [100%]	REVIEW	5/14/2021	APK
QUALITY	V	2.35	VERY GOOD [100%]			
FRAME	1	1.00	WOOD FRAME [100%]			

PHOTO 04/14/2014

BLDG COMMENTS

LLF=1RM, 1FBATH

YEAR BLT	2012	SIZE ADJ	1.000	ELEMENT	CD	DESCRIPTION	ADJ	S	BAT	T	DESCRIPTION	UNITS	YB	ADJ PRICE	RCN	TOTAL RCN	1,864,453
NET AREA	2,493	DETAIL ADJ	1.030	FOUNDATION	4	FLR & WALL	1.00	A	LLF	N	LOWER LEVEL FIN	836		402.52	336,511		
\$NLA(RCN)	\$748	OVERALL	1.000	EXT. COVER	1	WOOD SHINGLE	1.00	+	USF	L	UP-STRY FIN	1,421	2012	464.12	659,509		
				ROOF SHAPE	1	GABLE	1.00	+	BAS	L	BAS AREA	1,072	2012	546.96	586,344		
				ROOF COVER	1	ASPH/CMP SHIN	1.00	+	WDK	N	WOOD DECK	253		137.24	34,721		
				FLOOR COVER	1	HARDWOOD	1.00	D	BIG	N	BUILT-IN GARAGE	504		183.80	92,635		
				INT. FINISH	2	DRYWALL	1.00	F	LLU	N	LOWER LEVEL UN	210		308.19	64,719		
				HEATING/COOL	9	WARM/COOL AIR	1.03	F21	O		FPL 2S 1OP	1		24,383.60	24,384		
				FUEL SOURCE	2	GAS	1.00	GFP	O		GAS LOG/FP/E FP	2		14,620.55	29,241		
								ODS	O		OUT DOOR SHWR-A	1		3,471.00	3,471		

CONDITION ELEM	CD
EXTERIOR	A
INTERIOR	G
KITCHEN	G
BATHS	G
HEAT	A
ELECT	A

EFF.YR/AGE	2018 / 4	
COND	4	4 %
FUNC	0	
ECON	0	
DEPR	4	% GD 96
RCNLD	\$1,789,900	