

Key: 4608

Town of CHATHAM - Fiscal Year 2024

9/7/2023 9:38 am SEQ #: 5.037

LEGAL

LAND

DETACHED

BUILDING

CURRENT OWNER				PARCEL ID				LOCATION				
KING CANDYCE A 188 BAY VIEW RD S CHATHAM, MA 02659				3B-54-G17				188 BAY VIEW RD				
TRANSFER HISTORY				DOS	T	SALE PRICE	BK-PG (Cert)					
KING CANDYCE A				07/01/2019	A	400,000	(219859)					
KING CANDACE A & PERRY LE				07/01/2019	H		(219858)					
KING CANDACE A				06/29/1959	N		1 (23661)					
CD	T	AC/SF/UN	Nbhd	Inf1	Inf2	ADJ BASE	SAF	Inf3	Lpi	VC	CREDIT AMT	ADJ VALUE
100	S	7,465 SC	100	1.00	100	586,400	4.12	100	1.00	R05	1.60	414,000

CLASS	CLASS%	DESCRIPTION			BN ID	BN	CARD	
1010	100	SINGLE FAMILY				1	1 of 1	
PMT NO	PMT DT	TY	DESC	AMOUNT	INSP	BY	1st	%
21-087	01/27/2021	13	SH.MTL/FHAIR	10,000	03/18/2022	TCK	100	100
16-873	12/28/2016	10	Reroof	5,908	04/19/2017	NF	100	100
		50	Meas & List		03/04/2013	MR	100	100

TOTAL	7,465 SF	ZONING	R20	FRNT	108	ASSESSED	CURRENT	PREVIOUS
Nbhd	SOUTH CHATHAM	NOTE				LAND	414,000	345,000
Inf1	100		BUILDING	278,800	253,700			
Inf2	100		DETACHED	400	400			
			OTHER	0	0			
						TOTAL	693,200	599,100

TY	QUAL	COND	DIM/NOTE	YB	UNITS	ADJ PRICE	RCNLD
SHF	A	1.00 50 0.50	6X8		48	16.25	400

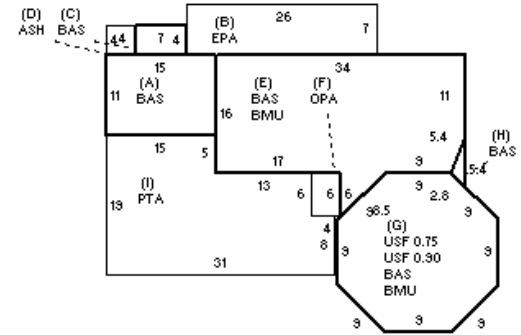

BUILDING	CD	ADJ	DESC	MEASURE	3/4/2022	TCK
MODEL	1		RESIDENTIAL	LIST	3/4/2022	EST
STYLE	7	1.00	OLD STYLE [100%]	REVIEW	3/31/2022	EMZ
QUALITY	-	0.80	MINUS AVE [100%]			
FRAME	1	1.00	WOOD FRAME [100%]			

BLDG COMMENTS

YEAR BLT	1959	SIZE ADJ	1.000	ELEMENT	CD	DESCRIPTION	ADJ	S	BAT	T	DESCRIPTION	UNITS	YB	ADJ PRICE	RCN	TOTAL RCN	435,618		
NET AREA	1,793	DETAIL ADJ	1.000	FOUNDATION	4	FLR & WALL	1.00	+	BAS	L	BAS AREA	1,148	1959	199.74	229,304	CONDITION ELEM	CD		
\$NLA(RCN)	\$243	OVERALL	1.000	EXT. COVER	1	WOOD SHINGLE	1.00	B	EPA	N	ENCL PORCH	182		106.96	19,466	EXTERIOR	A		
				ROOF SHAPE	1	GABLE	1.00	D	ASH	N	ATT SHED	16		48.50	776	INTERIOR	A		
				ROOF COVER	1	ASPH/CMP SHIN	1.00	+	BMU	N	BSMT UNFINISHED	948		58.63	55,582	KITCHEN	A		
				FLOOR COVER	34	CARPET/ASPH TL	1.00	F	OPA	N	OPEN PORCH	24		60.87	1,461	BATHS	A		
				INT. FINISH	2	DRYWALL	1.00	G	USF	L	UP-STRY FIN	645	1959	169.49	109,320	HEAT	A		
				HEATING/COOL	1	FORCED AIR	1.00	I	PTA	N	PATIO/STOOP	491		14.32	7,031	ELECT	A		
				FUEL SOURCE	2	GAS	1.00	BMG	O	O	BSMT GARAGE	1		2,216.00	2,216				
								F11	O	O	FPL 1S 10P	1		5,981.60	5,982				
				CAPACITY		UNITS	ADJ											EFF.YR/AGE	1968 / 54
				STORIES	2.5	1.00											COND	36 36 %	
				ROOMS	6	1.00											FUNC	0	
				BEDROOMS	3	1.00											ECON	0	
				FULL BATHS	2	1.00											DEPR	36 % GD 64	
				1/2 BATHS	0	1.00											RCNLD	\$278,800	
				FIXTURES	7	\$4,480													
				UNITS	1	1.00													