

Key: 5047

Town of CHATHAM - Fiscal Year 2024

9/7/2023 9:38 am SEQ #: 5.489

LEGAL

CURRENT OWNER				PARCEL ID				LOCATION			
LABONTE LISA 16 SYLVAN WAY S CHATHAM, MA 02659				4D-1-33				16 SYLVAN WAY			
TRANSFER HISTORY				DOS	T	SALE PRICE	BK-PG (Cert)				
LABONTE LISA				09/11/2012	A	99	26662-315				
LABONTE RONALD J				10/31/2001	A	1	14390-76				
LABONTE RONALD				02/03/1999	P	41,000	12041-283				

CLASS	CLASS%	DESCRIPTION			BN ID	BN	CARD	
1010	100	SINGLE FAMILY				1	1 of 1	
PMT NO	PMT DT	TY	DESC	AMOUNT	INSP	BY	1st	%
16-558	09/15/2016	4	Outbuildings		02/14/2019	TCK	100	100
	03/09/2009	50	Meas & List			RRC	100	100
1999015	02/01/1999	99	n/a				100	100
99-042	01/01/1999	99	n/a	120,000			100	100

LAND

CD	T	AC/SF/UN	Nbhd	Inf1	Inf2	ADJ BASE	SAF	Inf3	Lpi	VC	CREDIT AMT	ADJ VALUE	
100	S	20,436	MC	1.00	1.00	1.00	1.00	311,525	1.74	100	1.00	R01 0.85	254,840

DETACHED

TOTAL	20,436 SF	ZONING	R20	FRNT	0	ASSESSED	CURRENT	PREVIOUS
Nbhd	MID CHATHAM	NOTE				LAND	254,800	224,900
Inf1	100		BUILDING	366,300	338,100			
Inf2	100		DETACHED	3,900	3,000			
			OTHER	0	0			
						TOTAL	625,000	566,000

BUILDING

TY	QUAL	COND	DIM/NOTE	YB	UNITS	ADJ PRICE	RCNLD	PHOTO	10/29/2019
GHP	A	1.00	10 0.90	30X20PLANS	2018	600	5.64	3,000	
SHF	A	1.00	30 0.70	8X10		80	15.24	900	

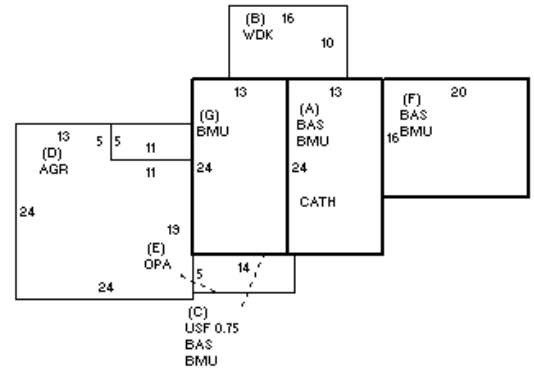

BUILDING	CD	ADJ	DESC	MEASURE	10/29/2019	NF
MODEL	1		RESIDENTIAL	LIST	10/29/2019	EST
STYLE	4	1.00	CAPE [100%]	REVIEW	12/9/2019	MR
QUALITY	A	1.00	AVERAGE [100%]			
FRAME	1	1.00	WOOD FRAME [100%]			

BLDG COMMENTS

YEAR BLT	1999	SIZE ADJ	1.000	ELEMENT	CD	DESCRIPTION	ADJ	S	BAT	T	DESCRIPTION	UNITS	YB	ADJ PRICE	RCN	TOTAL RCN	457,821
NET AREA	1,178	DETAIL ADJ	1.030	FOUNDATION	4	FLR & WALL	1.00	+	BMU	N	BSMT UNFINISHED	999		72.38	72,312		
\$NLA(RCN)	\$389	OVERALL	1.000	EXT. COVER	1	WOOD SHINGLE	1.00	+	BAS	L	BAS AREA	944	1999	282.89	267,044		
				ROOF SHAPE	1	GABLE	1.00	B	WDK	N	WOOD DECK	160		58.40	9,344		
				ROOF COVER	1	ASPH/CMP SHIN	1.00	C	USF	L	UP-STRY FIN	234	1999	240.04	56,169		
				FLOOR COVER	2	SOFTWOOD	1.00	D	AGR	N	ATTACHED GARAGE	521		77.95	40,613		
				INT. FINISH	2	DRYWALL	1.00	E	OPA	N	OPEN PORCH	70		76.10	5,327		
				HEATING/COOL	9	WARM/COOL AIR	1.03		MST	O	MASONRY STACK	1		2,068.00	2,068		
				FUEL SOURCE	2	GAS	1.00										
																CONDITION ELEM	CD
																EXTERIOR	A
																INTERIOR	G
																KITCHEN	A
																BATHS	A
																HEAT	A
																ELECT	A
																EFF.YR/AGE	2002 / 20
																COND	20 20 %
																FUNC	0
																ECON	0
																DEPR	20 % GD 80
																RCNLD	\$366,300