

Key: 5687

Town of CHATHAM - Fiscal Year 2024

9/7/2023 9:38 am SEQ #: 6.149

LEGALS AND

Table with columns: CURRENT OWNER, PARCEL ID, LOCATION, TRANSFER HISTORY, DOS, T, SALE PRICE, BK-PG (Cert), ADJ BASE, SAF, Inf1, Inf2, Lpi, VC, CREDIT AMT, ADJ VALUE.

Table with columns: CLASS, CLASS%, DESCRIPTION, BN ID, BN, CARD, PMT NO, PMT DT, TY, DESC, AMOUNT, INSP, BY, 1st, %.

Table with columns: TOTAL, ZONING, R60, FRNT, ASSESSED, CURRENT, PREVIOUS, Nbhd, Inf1, Inf2, LAND, BUILDING, DETACHED, OTHER, TOTAL.

Table with columns: TY, QUAL, COND, DIM/NOTE, YB, UNITS, ADJ PRICE, RCNLD, PHOTO 05/03/2021.

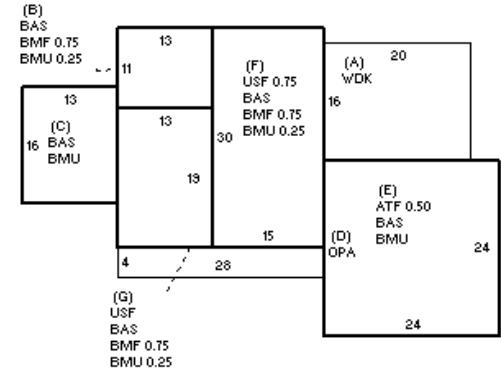

Table with columns: BUILDING, CD, ADJ, DESC, MEASURE, LIST, REVIEW, MODEL, STYLE, QUALITY, FRAME.

Table with columns: BLDG COMMENTS, MST=FLUE OPENING IN FINISHED BASEMENT.

BUILDING

Large summary table with columns: YEAR BLT, NET AREA, \$NLA(RCN), CAPACITY, UNITS, ADJ, ELEMENT, CD, DESCRIPTION, ADJ, S, BAT, T, DESCRIPTION, UNITS, YB, ADJ PRICE, RCN, TOTAL RCN, CONDITION ELEM, CD, EFF.YR/AGE, COND, FUNC, ECON, DEPR, RCNLD.