

Key: 6055

Town of CHATHAM - Fiscal Year 2024

9/7/2023 9:38 am SEQ #: 6.511

LEGAL

LAND

DETACHED

BUILDING

CURRENT OWNER				PARCEL ID				LOCATION			
THE GOOSE POND ROAD NOM TRUST LITTERIO LISA B & DENIS A TRSTES 234 WILDWOOD AVE BRAintree, MA 02184				6G-10-M26				16 GOOSE POND RD			
TRANSFER HISTORY				DOS	T	SALE PRICE	BK-PG (Cert)				
THE GOOSE POND ROAD NOM T				03/07/2022	A	1 (229328)					
CATTO ANTHONY J				10/24/2018	A	1 (53290)					
CATTO MARY MARGARET				12/13/1971	QS	1 (53290)					

CLASS	CLASS%	DESCRIPTION			BN ID	BN	CARD	
1010	100	SINGLE FAMILY				1	1 of 1	
PMT NO	PMT DT	TY	DESC	AMOUNT	INSP	BY	1st	%
21-196	03/03/2021	11	Window Rplc	4,000	03/31/2022	TCK	100	100
18-139	03/07/2019	11	Window Rplc	5,000	09/17/2019	NF	100	100
17-603	09/12/2017	10	Reroof	6,485	07/05/2018	NF	100	100
	02/17/2009	50	Meas & List			RRC	100	100
92-347		99	n/a	12,000			100	100

CD	T	AC/SF/UN	Nbhd	Inf1	Inf2	ADJ BASE	SAF	Inf3	Lpi	VC	CREDIT AMT	ADJ VALUE
100	S	15,227	MC	1.00	1.00	311,525	2.24	1.00	R01	0.85		243,560

TOTAL	15,227 SF	ZONING	R30	FRNT	0	ASSESSED	CURRENT	PREVIOUS
Nbhd	MID CHATHAM	NOTE				LAND	243,600	214,900
Inf1	100		BUILDING	165,300	150,400			
Inf2	100		DETACHED	0	0			
			OTHER	0	0			
			TOTAL	408,900	365,300			

TY	QUAL	COND	DIM/NOTE	YB	UNITS	ADJ PRICE	RCNLD

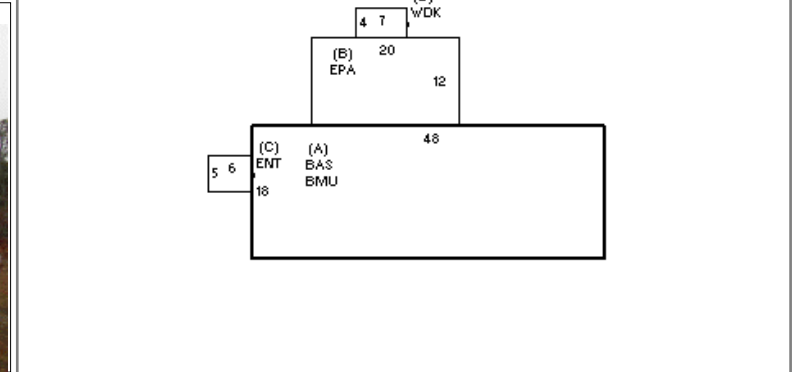

BUILDING	CD	ADJ	DESC	MEASURE	9/17/2019	NF
MODEL	1		RESIDENTIAL	LIST	9/17/2019	EST
STYLE	1	0.85	RANCH [100%]	REVIEW	4/18/2022	MR
QUALITY	-	0.80	MINUS AVE [100%]			
FRAME	1	1.00	WOOD FRAME [100%]			

BLDG COMMENTS

YEAR BLT	1958	SIZE ADJ	1.000	ELEMENT	CD	DESCRIPTION	ADJ	S	BAT	T	DESCRIPTION	UNITS	YB	ADJ PRICE	RCN	TOTAL RCN	266,579		
NET AREA	864	DETAIL ADJ	0.850	FOUNDATION	3	FOUND WALL	1.00	A	BMU	N	BSMT UNFINISHED	864		60.02	51,860	CONDITION ELEM	CD		
\$NLA(RCN)	\$309	OVERALL	1.000	EXT. COVER	1	WOOD SHINGLE	1.00	A	BAS	L	BAS AREA	864	1958	204.77	176,918	EXTERIOR	F		
				ROOF SHAPE	1	GABLE	1.00	B	EPA	N	ENCL PORCH	240		106.96	25,670	INTERIOR	A		
				ROOF COVER	1	ASPH/CMP SHIN	1.00	C	ENT	N	ENCL ENTRY	30		106.96	3,209	KITCHEN	A		
				FLOOR COVER	24	SOFTWD/ASPH TL	1.00	D	WDK	N	WOOD DECK	28		46.71	1,308	BATHS	A		
				INT. FINISH	2	DRYWALL	1.00		F11	O	FPL 1S 1OP	1		5,981.60	5,982	HEAT	A		
				HEATING/COOL	1	FORCED AIR	1.00									ELECT	A		
				FUEL SOURCE	2	GAS	1.00												
																		EFF.YR/AGE	1967 / 55
																		COND	38 38 %
																		FUNC	0
																		ECON	0
																		DEPR	38 % GD 62
																		RCNLD	\$165,300