

Key: 6106

Town of CHATHAM - Fiscal Year 2024

9/7/2023 9:38 am SEQ #: 6.562

LEGAL

LAND

DETACHED

BUILDING

CURRENT OWNER				PARCEL ID				LOCATION			
HARRIS MARIANNE B & BAKEMAN WILLIAM H				6I-18-N17				211 COUNTRY SIDE DR			
211 COUNTRY SIDE DR				TRANSFER HISTORY				DOS T SALE PRICE BK-PG (Cert)			
CHATHAM, MA 02633				HARRIS MARIANNE B & BAKEM				11/01/2016 A 1 30057-174			
				HARRIS MARIANNE B 1/2 T/C				04/12/2016 A 1 29574-296			
				HARRIS MARIANNE B				12/04/2009 A 1 24212-279			

CLASS	CLASS%	DESCRIPTION			BN ID	BN	CARD	
1010	100	SINGLE FAMILY				1	1 of 1	
PMT NO	PMT DT	TY	DESC	AMOUNT	INSP	BY	1st	%
17-670	10/05/2017	2	Additions	140,000	01/22/2019	TCK	100	100
14-377	07/01/2014	10	Reroof	6,980	05/14/2015	MW	100	100
	02/18/2009	50	Meas & List			RRC	100	100
05-579	11/28/2005	99	n/a	22,000			100	100
1983222	12/07/1983	99	n/a				100	100

CD	T	AC/SF/UN	Nbhd	Inf1	Inf2	ADJ BASE	SAF	Inf3	Lpi	VC	CREDIT AMT	ADJ VALUE	
100	S	29,080	MC	1.00	1.00	1.00	1.00	403,150	1.30	100	1.00	RF2 1.10	349,530

TOTAL	29,080 SF	ZONING	R60	FRNT	0	ASSESSED	CURRENT	PREVIOUS
Nbhd	MID CHATHAM	NOTE				LAND	349,500	291,300
Inf1	100		BUILDING	591,300	538,000			
Inf2	100		DETACHED	0	0			
			OTHER	0	0			
						<b>TOTAL</b>	<b>940,800</b>	<b>829,300</b>

TY	QUAL	COND	DIM/NOTE	YB	UNITS	ADJ PRICE	RCNLD

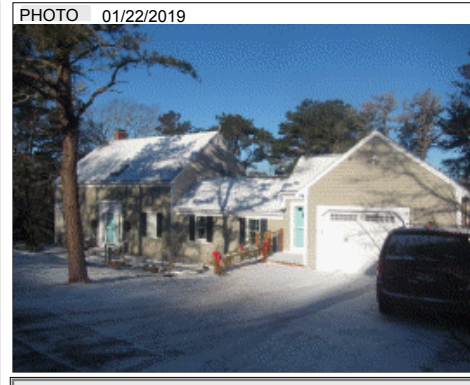

BLDG COMMENTS
SCUTTLE ATTIC

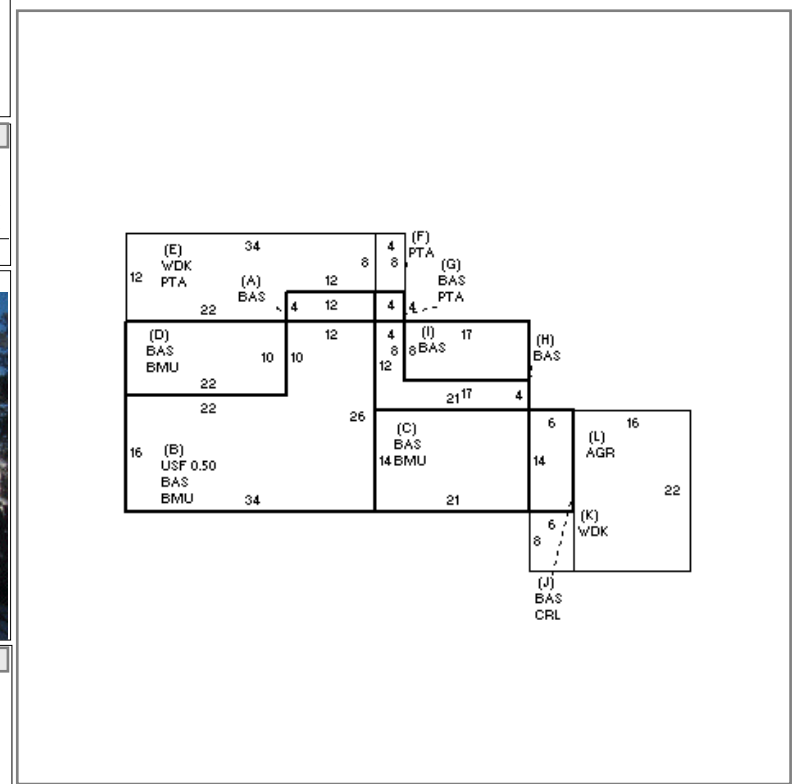

BUILDING	CD	ADJ	DESC	MEASURE	7/11/2018	NF
MODEL	1		RESIDENTIAL	LIST	7/19/2018	NF
STYLE	4	1.00	CAPE [100%]	REVIEW	4/30/2019	TD
QUALITY	+	1.20	PLUS AVE [100%]			
FRAME	1	1.00	WOOD FRAME [100%]			

YEAR BLT	1984	SIZE ADJ	1.000	ELEMENT	CD	DESCRIPTION	ADJ	S	BAT	T	DESCRIPTION	UNITS	YB	ADJ PRICE	RCN	TOTAL RCN	767,904
NET AREA	1,910	DETAIL ADJ	1.050	FOUNDATION	4	FLR & WALL	1.00	+	BAS	L	BAS AREA	1,342	1984	310.78	417,068	CONDITION ELEM	CD
\$NLA(RCN)	\$402	OVERALL	1.000	EXT. COVER	1	WOOD SHINGLE	1.00	+	BMU	N	BSMT UNFINISHED	1,178		82.68	97,403	EXTERIOR	A
				ROOF SHAPE	1	GABLE	1.00	B	USF	L	UP-STRY FIN	332	1984	263.71	87,551	INTERIOR	A
				ROOF COVER	1	ASPH/CMP SHIN	1.00	+	PTA	N	PATIO/STOOP	408		21.48	8,764	KITCHEN	A
				FLOOR COVER	13	HARDWD/CARPET	1.00	+	BAS	L	BAS AREA	236	2017	310.78	73,344	BATHS	A
				INT. FINISH	2	DRYWALL	1.00	J	CRL	N	CRAWL SPACE	84		24.59	2,065	HEAT	A
				HEATING/COOL	11	HT-WT/COOL AIR	1.05	+	WDK	N	WOOD DECK	408		70.08	28,592	ELECT	A
				FUEL SOURCE	2	GAS	1.00	L	AGR	N	ATTACHED GARAGE	352		98.35	34,618		
									F21	O	FPL 2S 1OP	1		12,451.20	12,451		

EFF.YR/AGE	1994 / 28
COND	23 23 %
FUNC	0
ECON	0
DEPR	23 % GD 77
RCNLD	\$591,300