

Key: 6607

Town of CHATHAM - Fiscal Year 2024

9/7/2023 9:38 am SEQ #: 7.079

LEG
A
L
L
A
N
D

CURRENT OWNER				PARCEL ID				LOCATION				
DONOGHUE MICHAEL & ROSE NOW YAN WILLIAM L & RUTH LIU 101 COTTONWOOD LN CENTERVILLE, MA 02632				7K-2-C55				595 RIVERVIEW DR				
TRANSFER HISTORY				DOS	T	SALE PRICE	BK-PG (Cert)					
YAN WILLIAM L & RUTH LIU				06/16/2023	QS	1,600,000	(233198)					
DONOGHUE MICHAEL & ROSE				12/04/2020	QS	879,000	(224642)					
JANICE M TRAVIS LIVING TR				11/19/2008	A	1	(187390)					
CD	T	AC/SF/UN	Nbhd	Inf1	Inf2	ADJ BASE	SAF	Inf3	Lpi	VC	CREDIT AMT	ADJ VALUE
100	S	40,000	MC	1.00	100	1.00	100	1.00	RV1	1.30		437,510
300	A	0.121	MC	1.00	100	1.00	100	1.00	RV1	1.30		3,020

CLASS	CLASS%	DESCRIPTION			BN ID	BN	CARD	
1010	100	SINGLE FAMILY				1	1 of 1	
PMT NO	PMT DT	TY	DESC	AMOUNT	INSP	BY	1st	%
22-521	07/12/2023	98	SALES QUESTI				100	100
	04/13/2023	3	Renovations				100	100
	06/22/2022	99	n/a	5,921			100	100
	07/06/2005	50	Meas & List			JB	100	100
000000668	10/25/2004	10	Reroof	4,000			100	100

TOTAL	1.039 Acres	ZONING	R60	FRNT	0	ASSESSED	CURRENT	PREVIOUS
Nbhd	MID CHATHAM	N O T E	Abuts Conservation Area View-			LAND	440,500	451,800
Inf1	100		LAND	926,400	616,600			
Inf2	100		OTHER	0	0			
TOTAL						1,366,900	1,068,400	

TY	QUAL	COND	DIM/NOTE	YB	UNITS	ADJ PRICE	RCNLD

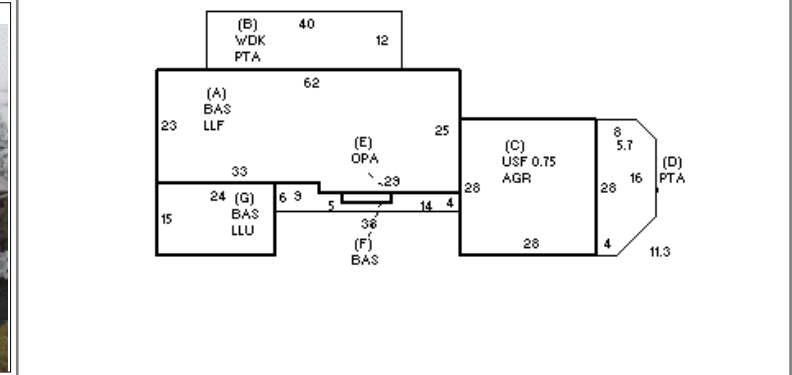

BUILDING	CD	ADJ	DESC	MEASURE	1/3/2020	TCK
MODEL	1		RESIDENTIAL	LIST	1/17/2020	NF
STYLE	1	0.85	RANCH [100%]	REVIEW	2/7/2020	MR
QUALITY	+	1.20	PLUS AVE [100%]			
FRAME	1	1.00	WOOD FRAME [100%]			

BLDG COMMENTS
LLF-FAM RM, BATH, WD STOVE, OFFICE, BDRM

D
E
T
A
C
H
E
D

B
U
I
L
D
I
N
G

YEAR BLT	1980	SIZE ADJ	1.000	ELEMENT	CD	DESCRIPTION	ADJ	S	BAT	T	DESCRIPTION	UNITS	YB	ADJ PRICE	RCN	TOTAL RCN	1,006,986		
NET AREA	2,452	DETAIL ADJ	0.875	FOUNDATION	4	FLR & WALL	1.00	A	LLF	N	LOWER LEVEL FIN	1,484		171.30	254,208	CONDITION ELEM CD			
\$NLA(RCN)	\$411	OVERALL	1.000	EXT. COVER	1	WOOD SHINGLE	1.00	+	PTA	N	PATIO/STOOP	776		21.48	16,668	EXTERIOR	G		
CAPACITY				ROOF SHAPE	1	GABLE	1.00	B	WDK	N	WOOD DECK	480		70.08	33,638	INTERIOR	G		
STORIES	1.75	1.00	ROOF COVER	1	ASPH/CMP SHIN	1.00	1.00	C	AGR	N	ATTACHED GARAGE	784		90.20	70,718	KITCHEN	V		
ROOMS	8	1.00	FLOOR COVER	1	HARDWOOD	1.00	1.00	C	USF	L	UP-STRY FIN	588	2004	197.51	116,137	BATHS	G		
BEDROOMS	5	1.00	INT. FINISH	2	DRYWALL	1.00	1.00	E	OPA	N	OPEN PORCH	150		91.32	13,698	HEAT	U		
FULL BATHS	4	1.00	HEATING/COOL	9	WARM/COOL AIR	1.03	1.03	+	BAS	L	BAS AREA	1,864	1980	232.77	433,879	ELECT	U		
1/2 BATHS	0	1.00	FUEL SOURCE	2	GAS	1.00	1.00	G	LLU	N	LOWER LEVEL UN	360		131.15	47,214				
FIXTURES	12	\$10,080																	
UNITS	1	1.00																	
												F11	O	FPL 1S 1OP	1	8,972.40	8,972		
												GEN	O	GENERATOR	1	0.00			
												ODS	O	OUT DOOR SHWR-A	1	1,772.40	1,772		
																EFF.YR/AGE	2014 / 8		
																COND	8 8 %		
																FUNC	0		
																ECON	0		
																DEPR	8 % GD 92		
																RCNLD	\$926,400		