

Key: 6785

Town of CHATHAM - Fiscal Year 2024

9/7/2023 9:38 am SEQ #: 7.262

LEGAL LAND

CURRENT OWNER		PARCEL ID				LOCATION			
THE MARY MCCAULEY REV TRUST AGGMT & THE PATRICK MCCAULEY REV TRUST AGGMT 101 GERANIUM DR CHATHAM, MA 02633		8D-20-7				101 GERANIUM DR			
		TRANSFER HISTORY				DOS	T	SALE PRICE	BK-PG (Cert)
		THE MARY MCCAULEY REV TRU				01/21/2022	A	1 34845-332	
MCCAULEY MARY & PATRICK				12/06/2021	A	1 34724-218			
MARY MCCAULEY RT & PATRIC				07/16/2007	A	9 22190-163			

CLASS	CLASS%	DESCRIPTION			BN ID	BN	CARD	
1010	100	SINGLE FAMILY				1	1 of 1	
PMT NO	PMT DT	TY	DESC	AMOUNT	INSP	BY	1st	%
22-1065	12/20/2022	11	Window Rplc	25,148	04/04/2023	NF	100	100
15-029	01/21/2015	12	INSULATION	3,100		APK	100	100
	01/09/2006	50	Meas & List			JB	100	100
1996272	11/21/1996	99	n/a				100	100

LEGAL LAND

CD	T	AC/SF/UN	Nbhd	Inf1	Inf2	ADJ BASE	SAF	Inf3	Lpi	VC	CREDIT AMT	ADJ VALUE
100	S	40,000	SC	1.00	100	769,650	1.00	100	1.00	CF1	2.10	706,750
300	A	3,501	SC	1.00	10	4,032	1.00	100	1.00	CF1	2.10	14,120

TOTAL	4.419 Acres				ZONING	R20	FRNT	0	ASSESSED	CURRENT	PREVIOUS
Nbhd	SOUTH CHATHAM				N O T E	Vw/low, wet OBSTR VIEW PARTIAL			LAND	720,900	600,700
Inf1	100					LAND	166,300	151,300	BUILDING	15,800	15,100
Inf2	100					OTHER	0	0	OTHER	0	0
TOTAL								TOTAL	903,000	767,100	

DETACHED

TY	QUAL	COND	DIM/NOTE	YB	UNITS	ADJ PRICE	RCNLD
SHF	A	1.00	40 0.60	1960	320	10.84	2,100
CBN	+	1.10	20 0.80	1960	384	44.68	13,700

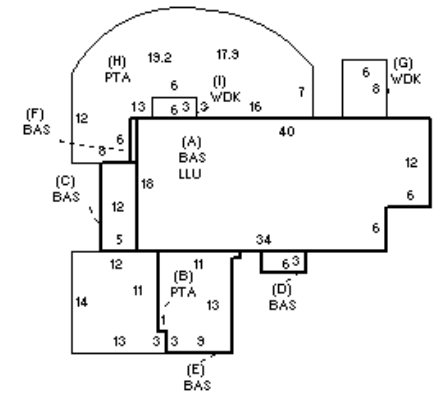

BLDG COMMENTS

BUILDING

BUILDING	CD	ADJ	DESC	MEASURE	12/15/2021	TCK
MODEL	1		RESIDENTIAL	LIST	12/15/2021	EST
STYLE	1	0.85	RANCH [100%]	REVIEW	4/19/2023	EMZ
QUALITY	-	0.80	MINUS AVE [100%]			
FRAME	1	1.00	WOOD FRAME [100%]			

YEAR BLT	1952	SIZE ADJ	1.000	ELEMENT	CD	DESCRIPTION	ADJ	S	BAT	T	DESCRIPTION	UNITS	YB	ADJ PRICE	RCN	TOTAL RCN	251,966			
NET AREA	906	DETAIL ADJ	0.875	FOUNDATION	4	FLR & WALL	1.00	A	LLU	N	LOWER LEVEL UN	684		100.86	68,990	CONDITION ELEM	CD			
\$NLA(RCN)	\$278	OVERALL	1.000	EXT. COVER	1	WOOD SHINGLE	1.00	+	PTA	N	PATIO/STOOP	619		14.32	8,864	EXTERIOR	G			
				ROOF SHAPE	1	GABLE	1.00	+	BAS	L	BAS AREA	906	1952	179.01	162,185	INTERIOR	A			
				ROOF COVER	1	ASPH/CMP SHIN	1.00	+	WDK	N	WOOD DECK	66		46.72	3,083	KITCHEN	A			
				FLOOR COVER	34	CARPET/ASPH TL	1.00		F11	O	FPL 1S 1OP	1		5,981.60	5,982	BATHS	A			
				INT. FINISH	2	DRYWALL	1.00		GEN	O	GENERATOR	1		0.00		BATHS	A			
				HEATING/COOL	9	WARM/COOL AIR	1.03		ODS	O	OUT DOOR SHWR-A	1		1,181.60	1,182	HEAT	A			
				FUEL SOURCE	2	GAS	1.00									ELECT	A			
																		EFF.YR/AGE	1970 / 52	
																		COND	34 34 %	
																		FUNC	0	
																		ECON	0	
																		DEPR	34 % GD 66	
																		RCNLD	\$166,300	