

Key: 7034

Town of CHATHAM - Fiscal Year 2024

9/7/2023 9:38 am SEQ #: 7.516

LEGAL

LAND

DETACHED

BUILDING

CURRENT OWNER		PARCEL ID		LOCATION	
THE GARY & JANET TOENNIENSEN 2022 JT TOENNIENSEN GARY H & JANET S TRSTES 889 OLD QUEEN ANNE RD CHATHAM, MA 02633		8H-34-T2		889 OLD QUEEN ANNE RD	
TRANSFER HISTORY		DOS	T	SALE PRICE	BK-PG (Cert)
THE GARY & JANET TOENNIES TOENNIENSEN GARY H & JANE MILLER CHRISTINE P		11/01/2022 01/31/2013 08/10/2009	A QS H	1 1,850,000 23953-303	35458-347 27095-171 23953-303

CLASS	CLASS%	DESCRIPTION		BN ID	BN	CARD	
1010	100	SINGLE FAMILY			1	1 of 1	
PMT NO	PMT DT	TY	DESC	AMOUNT	INSP	BY	1st %
22-585	07/18/2022	10	Reroof	188,000	05/12/2003	NF	100 100
17-154	03/16/2017	3	Renovations		07/12/2018	NF	100 100
	02/27/2008	50	Meas & List			RRC	100 100
07-163	04/25/2007	3	Renovations	200,000	02/27/2008		100 100
	02/08/2007	50	Meas & List			RRC	100 100

CD	T	AC/SF/UN	Nbhd	Inf1	Inf2	ADJ BASE	SAF	Inf3	Lpi	VC	CREDIT AMT	ADJ VALUE
100	S	40,000	MC	1.00	100	733,000	1.00	100	1.00	PF5	2.00	673,090
300	A	0.431	MC	1.00	100	38,400	1.00	100	1.00	PF5	2.00	16,550

TOTAL	1.349 Acres	ZONING	R60	FRNT	0	ASSESSED	CURRENT	PREVIOUS
Nbhd	MID CHATHAM	N O T E	Pond Front.			LAND	689,600	574,700
Inf1	100		LAND BUILDING	2,492,300	1,971,700			
Inf2	100		DETACHED	65,700	62,700			
			OTHER	0	0			
			TOTAL	3,247,600	2,609,100			

TY	QUAL	COND	DIM/NOTE	YB	UNITS	ADJ PRICE	RCNLD
GFL	G	1.20	10 0.90	GFP ?	1994	720	89.21
STR	A	1.00	10 0.90	W/TWO 4X6'LA	1996	294	30.00



BLDG COMMENTS

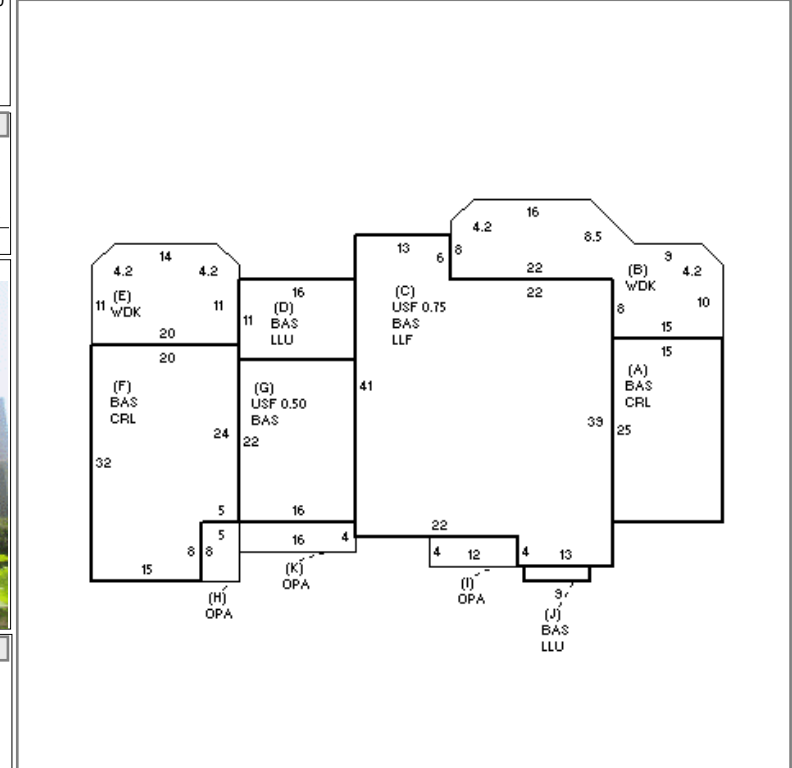

BUILDING	CD	ADJ	DESC	MEASURE
MODEL	1		RESIDENTIAL	
STYLE	8	0.95	CONTEMPORARY [100%]	LIST
QUALITY	V	2.35	VERY GOOD [100%]	REVIEW
FRAME	1	1.00	WOOD FRAME [100%]	5/25/2023 EMZ

YEAR BLT	1995	SIZE ADJ	1.000	ELEMENT	CD	DESCRIPTION	ADJ	S	BAT	T	DESCRIPTION	UNITS	YB	ADJ PRICE	RCN	TOTAL RCN	2,769,210
NET AREA	4,068	DETAIL ADJ	0.978	FOUNDATION	4	FLR & WALL	1.00	+	CRL	N	CRAWL SPACE	975		50.88	49,611	CONDITION ELEM	CD
\$NLA(RCN)	\$681	OVERALL	1.000	EXT. COVER	1	WOOD SHINGLE	1.00	+	BAS	L	BAS AREA	2,524	1995	499.06	1,259,633	EXTERIOR	G
CAPACITY		UNITS	ADJ	ROOF SHAPE	1	GABLE	1.00	+	WDK	N	WOOD DECK	699		137.24	95,932	INTERIOR	G
STORIES	1.75	1.00	ROOF COVER	1	ASPH/CMP SHIN	1.00	1.00	C	LLF	N	LOWER LEVEL FIN	1,355		367.27	497,653	KITCHEN	G
ROOMS	9	1.00	FLOOR COVER	13	HARDWD/CARPET	1.00	1.00	C	USF	L	UP-STRY FIN	1,016	1995	423.47	430,247	BATHS	G
BEDROOMS	4	1.00	INT. FINISH	2	DRYWALL	1.00	1.00	+	LLU	N	LOWER LEVEL UN	194		281.19	54,551	HEAT	A
FULL BATHS	4	1.00	HEATING/COOL	9	WARM/COOL AIR	1.03	1.03	G	BAS	L	BAS AREA	352	2007	499.06	175,670	ELECT	U
1/2 BATHS	1	1.00	FUEL SOURCE	2	GAS	1.00	1.00	G	USF	L	UP-STRY FIN	176	2007	423.47	74,530		
FIXTURES	15	\$27,580						+	OPA	N	OPEN PORCH	152		178.83	27,183	EFF.YR/AGE	2012 / 10
UNITS	1	1.00						F21	O	FPL 2S 1OP	1		24,383.60	24,384	COND	10 10 %	
								F22	O	FPL 2S 2OP	1		34,145.50	34,146	FUNC	0	
								GFP	O	GAS LOG/FP/E FP	1		14,621.70	14,622	ECON	0	
								ODS	O	OUT DOOR SHWR-A	1		3,471.00	3,471	DEPR	10 % GD 90	
															RCNLD	\$2,492,300	