

Key: 7067

Town of CHATHAM - Fiscal Year 2024

9/7/2023 9:38 am SEQ #: 7.550

LEG
AL
LAND

CURRENT OWNER				PARCEL ID				LOCATION				
VITEK ANDREW S & MELISSA A 1521 OLD WELSH RD HUNTINGTON VALLEY, PA 19006				81-30-C266				55 TROUT POND LN				
TRANSFER HISTORY				DOS	T	SALE PRICE	BK-PG (Cert)					
VITEK ANDREW S & MELISSA				09/30/2020	QS	615,000	(223917)					
MOSS ROBERT A JR				04/08/2011	QS	540,000	(194006)					
MOHR CHESTER JR & JOAN				01/16/1985	QS	30,000	(99916)					
CD	T	AC/SF/UN	Nbhd	Inf1	Inf2	ADJ BASE	SAF	Inf3	Lpi	VC	CREDIT AMT	ADJ VALUE
100	S	23,485	MC	1.00	1.00	366,500	1.55	100	1.00	R03	1.00	306,590

CLASS	CLASS%	DESCRIPTION			BN ID	BN	CARD	
1010	100	SINGLE FAMILY				1	1 of 1	
PMT NO	PMT DT	TY	DESC	AMOUNT	INSP	BY	1st	%
16-649	11/02/2020	98	SALES QUESTI				100	100
	10/17/2019	3	Renovations		10/17/2019	APK	100	100
	10/14/2016	10	Reroof	9,150	06/07/2017	NF	100	100
	02/08/2010	50	Meas & List			RRC	100	100
1990012	01/29/1990	99	n/a				100	100

LAND

TOTAL	23,485 SF	ZONING	R60	FRNT	0	ASSESSED	CURRENT	PREVIOUS
Nbhd	MID CHATHAM	NOTE Right to use Park L82,97 + 136				LAND	306,600	255,500
Inf1	100		BUILDING	698,500	635,800			
Inf2	100		OTHER	0	0			
						TOTAL	1,005,100	891,300

DETACHED

TY	QUAL	COND	DIM/NOTE	YB	UNITS	ADJ PRICE	RCNLD

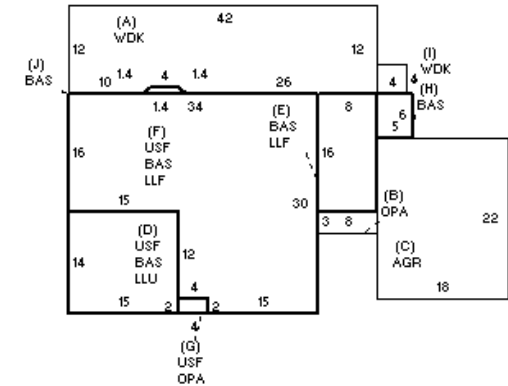

BUILDING

BUILDING	CD	ADJ	DESC	MEASURE	12/10/2019	TCK
MODEL	1		RESIDENTIAL	LIST	12/10/2019	EST
STYLE	5	1.00	COLONIAL [100%]	REVIEW	12/13/2019	MR
QUALITY	+	1.20	PLUS AVE [100%]			
FRAME	1	1.00	WOOD FRAME [100%]			

BLDG COMMENTS

INDING

YEAR BLT	1988	SIZE ADJ	1.000	ELEMENT	CD	DESCRIPTION	ADJ	S	BAT	T	DESCRIPTION	UNITS	YB	ADJ PRICE	RCN	TOTAL RCN	884,177
NET AREA	2,195	DETAIL ADJ	1.000	FOUNDATION	4	FLR & WALL	1.00	+	WDK	N	WOOD DECK	515		70.08	36,091		
\$NLA(RCN)	\$403	OVERALL	1.000	EXT. COVER	1	WOOD SHINGLE	1.00	+	OPA	N	OPEN PORCH	32		91.31	2,922		
				ROOF SHAPE	1	GABLE	1.00	C	AGR	N	ATTACHED GARAGE	396		96.68	38,284		
				ROOF COVER	1	ASPH/CMP SHIN	1.00	D	LLU	N	LOWER LEVEL UN	210		153.81	32,300		
				FLOOR COVER	1	HARDWOOD	1.00	+	USF	L	UP-STRY FIN	1,020	1988	231.63	236,267		
				INT. FINISH	2	DRYWALL	1.00	+	LLF	N	LOWER LEVEL FIN	930		200.89	186,830		
				HEATING/COOL	2	HOT WATER	1.00	H	BAS	L	BAS AREA	30	2019	273.00	8,190		
				FUEL SOURCE	2	GAS	1.00	+	BAS	L	BAS AREA	1,145	1988	272.98	312,564		
									F22	O	FPL 2S ZOP	1		17,436.00	17,436		
									ODS	O	OUT DOOR SHWR-A	1		1,772.40	1,772		
																EFF.YR/AGE	2000 / 22
																COND	21 21 %
																FUNC	0
																ECON	0
																DEPR	21 % GD 79
																RCNLD	\$698,500