

Key: 7129

Town of CHATHAM - Fiscal Year 2024

9/7/2023 9:38 am SEQ #: 7.612

LEGALS

CURRENT OWNER										PARCEL ID				LOCATION			
2014 DJN TRUST & 2014 JHN TRUST NICHOLS DOUGLAS J & JUDITH H TRSTES 47 MONOMESSAT WAY CHATHAM, MA 02633										8J-27-C300				47 MONOMESSAT WAY			
TRANSFER HISTORY										DOS		T		SALE PRICE		BK-PG (Cert)	
2014 DJN TRUST & 2014 JHN										12/03/2014		A		1 (205097)			
NICHOLS DOUGLAS J & JUDITH										10/14/2003		A		1 (170890)			
NICHOLS GEORGE HEIRS										10/13/2003		A		1 (170889)			

CLASS	CLASS%	DESCRIPTION			BN ID	BN	CARD	
1010	100	SINGLE FAMILY				1	1 of 1	
PMT NO	PMT DT	TY	DESC	AMOUNT	INSP	BY	1st	%
14-260	05/12/2014	11	Window Rplc	5,739	05/12/2015	MW	100	100
14-228	04/29/2014	3	Renovations	3,700	05/12/2015	MW	100	100
02-656	02/26/2004	50	Meas & List			RRC	100	100
	12/19/2003	99	n/a	20,000			100	100

LAND

CD	T	AC/SF/UN	Nbhd	Inf1	Inf2	ADJ BASE	SAF	Inf3	Lpi	VC	CREDIT AMT	ADJ VALUE
100	S	21,742	MC	1.00	100	1.00	100	1.00	R03	1.00		302,800

TOTAL	21,742 SF	ZONING	R60	FRNT	0	ASSESSED	CURRENT	PREVIOUS
Nbhd	MID CHATHAM	NOTE				LAND	302,800	252,300
Inf1	100		BUILDING	595,200	541,600			
Inf2	100		DETACHED	0	0			
			OTHER	0	0			
						TOTAL	898,000	793,900

DETACHED

TY	QUAL	COND	DIM/NOTE	YB	UNITS	ADJ PRICE	RCNLD	PHOTO	12/05/2019
									

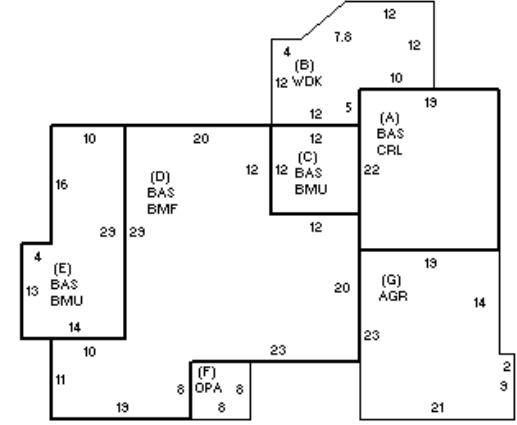

BUILDING

BUILDING	CD	ADJ	DESC	MEASURE	12/5/2019	TCK	BLDG COMMENTS
MODEL	1		RESIDENTIAL	LIST	12/11/2019	NF	PULL DOWN STAIRS TO ATTIC
STYLE	1	0.85	RANCH [100%]	REVIEW	1/15/2020	MR	BMF=OFFICE, FAM RM
QUALITY	+	1.20	PLUS AVE [100%]				
FRAME	1	1.00	WOOD FRAME [100%]				

YEAR BLT	1984	SIZE ADJ	1.000	ELEMENT	CD	DESCRIPTION	ADJ	S	BAT	T	DESCRIPTION	UNITS	YB	ADJ PRICE	RCN	TOTAL RCN	804,330
NET AREA	1,966	DETAIL ADJ	0.892	FOUNDATION	4	FLR & WALL	1.00	A	CRL	N	CRAWL SPACE	418		26.45	11,058		
\$NLA(RCN)	\$409	OVERALL	1.000	EXT. COVER	1	WOOD SHINGLE	1.00	+	BAS	L	BAS AREA	1,966	1984	262.67	516,402		
				ROOF SHAPE	1	GABLE	1.00	B	WDK	N	WOOD DECK	289		70.08	20,254		
				ROOF COVER	1	ASPH/CMP SHIN	1.00	+	BMU	N	BSMT UNFINISHED	486		88.95	43,229		
				FLOOR COVER	3	W/W CARPET	1.00	D	BMF	N	BSMT FINISH-SEP	1,062		130.32	138,400		
				INT. FINISH	2	DRYWALL	1.00	F	OPA	N	OPEN PORCH	64		91.31	5,844		
				HEATING/COOL	11	HT-WT/COOL AIR	1.05	G	AGR	N	ATTACHED GARAGE	455		95.00	43,226		
				FUEL SOURCE	2	GAS	1.00	F11	O		FPL 1S 1OP	1		8,972.40	8,972		
								GFP	O		GAS LOG/FP/E FP	1		7,466.40	7,466		
								ODS	O		OUT DOOR SHWR-A	1		1,772.40	1,772		

CONDITION ELEM	CD
EXTERIOR	A
INTERIOR	A
KITCHEN	A
BATHS	A
HEAT	A
ELECT	A

EFF.YR/AGE	1984 / 38
COND	26 26%
FUNC	0
ECON	0
DEPR	26 % GD 74

RCNLD	\$595,200
-------	-----------