

Key: 745

Town of CHATHAM - Fiscal Year 2024

9/7/2023 9:38 am SEQ #: 831

LEGAL

LAND

DETACHED

BUILDING

CURRENT OWNER										PARCEL ID				LOCATION			
MIRIAM SONIA IKLE-KHALSA LIVING TRUST SAT JIWAN SINGH IKLE-KHALSA LIVING TRUST 21 BALTIMORE ST MILLIS, MA 02054										11F-9H-B9				110 BALFOUR LN			
TRANSFER HISTORY										DOS	T	SALE PRICE	BK-PG (Cert)				
MIRIAM SONIA IKLE-KHALSA										11/04/2011	QS	470,000	25814-16				
ROPER KATHLEEN J										10/19/2001	QS	375,000	14345-125				
VAUGHN JANE A										12/26/1991	QS	218,750	7810-235				

CLASS	CLASS%	DESCRIPTION			BN ID	BN	CARD	
1010	100	SINGLE FAMILY				1	1 of 1	
PMT NO	PMT DT	TY	DESC	AMOUNT	INSP	BY	1st	%
12-233	05/03/2012	8	Cyc. Reinsp.		12/16/2021	NF	100	100
	04/03/2007	99	n/a	2,000	04/11/2014	SF	100	100
96-269	06/01/1996	50	Meas & List			RRC	100	100
		14	DECK	1,000			100	100

CD	T	AC/SF/UN	Nbhd	Inf1	Inf2	ADJ BASE	SAF	Inf3	Lpi	VC	CREDIT AMT	ADJ VALUE
100	S	20,539	MC	1.00	1.00	366,500	1.74	1.00	1.00	R02	1.00	300,060

TOTAL	20,539 SF	ZONING	R20	FRNT	120	ASSESSED	CURRENT	PREVIOUS
Nbhd	MID CHATHAM	NOTE			LAND	300,100	250,000	
Inf1	100		BUILDING	470,200	433,900			
Inf2	100		DETACHED	0	0			
			OTHER	0	0			
TOTAL						770,300	683,900	

TY	QUAL	COND	DIM/NOTE	YB	UNITS	ADJ PRICE	RCNLD



BLDG COMMENTS

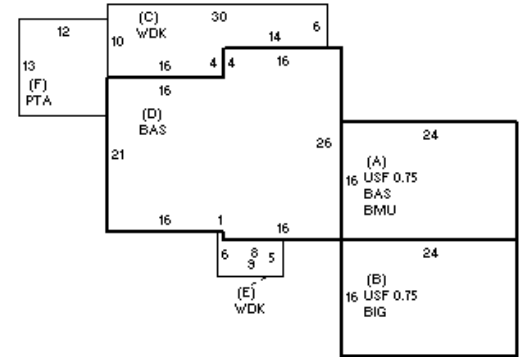

BUILDING	CD	ADJ	DESC	MEASURE	12/16/2021	NF
MODEL	1		RESIDENTIAL	LIST	12/16/2021	EST
STYLE	4	1.00	CAPE [100%]	REVIEW	1/24/2022	EMZ
QUALITY	+	1.20	PLUS AVE [100%]			
FRAME	1	1.00	WOOD FRAME [100%]			

YEAR BLT	1987	SIZE ADJ	1.000	ELEMENT	CD	DESCRIPTION	ADJ	S	BAT	T	DESCRIPTION	UNITS	YB	ADJ PRICE	RCN
NET AREA	1,712	DETAIL ADJ	1.050	FOUNDATION	4	FLR & WALL	1.00	A	BMU	N	BSMT UNFINISHED	384		108.58	41,693
\$NLA(RCN)	\$371	OVERALL	1.000	EXT. COVER	1	WOOD SHINGLE	1.00	+	USF	L	UP-STRY FIN	576	1987	269.37	155,158
				ROOF SHAPE	1	GABLE	1.00	B	BIG	N	BUILT-IN GARAGE	384		97.09	37,283
				ROOF COVER	1	ASPH/CMP SHIN	1.00	+	WDK	N	WOOD DECK	290		70.08	20,323
				FLOOR COVER	16	HARDWD/OTHER	1.00	+	BAS	L	BAS AREA	1,136	1987	317.45	360,628
				INT. FINISH	2	DRYWALL	1.00	F	PTA	N	PATIO/STOOP	156		21.48	3,350
				HEATING/COOL	11	HT-WT/COOL AIR	1.05	F11	O	O	FPL 1S 10P	1		8,972.40	8,972
				FUEL SOURCE	2	GAS	1.00								

TOTAL RCN	635,471
CONDITION ELEM	CD
EXTERIOR	A
INTERIOR	A
KITCHEN	A
BATHS	A
HEAT	A
ELECT	A
EFF.YR/AGE	1987 / 35
COND	26 26 %
FUNC	0
ECON	0
DEPR	26 % GD 74
RCNLD	\$470,200