

Key: 7661

Town of CHATHAM - Fiscal Year 2024

9/7/2023 9:38 am SEQ #: 8.175

LEGAL

LAND

DETACHED

BUILDING

CURRENT OWNER				PARCEL ID				LOCATION				
BOSWORTH TODD & IRENA 17 LAMPLIGHT CIR NATICK, MA 01760				9K-37-H7				42 ECHO ST				
TRANSFER HISTORY				DOS	T	SALE PRICE	BK-PG (Cert)					
BOSWORTH TODD & IRENA				10/27/2016	QS	520,000	30040-345					
42 ECHO STREET NOMINEE TR				02/03/2012	A	1	26056-133					
HARLEY HUGH J & DONNA C				05/01/2002	A	160,000	15115-158					
CD	T	AC/SF/UN	Nbhd	Inf1	Inf2	ADJ BASE	SAF	Inf3	Lpi	VC	CREDIT AMT	ADJ VALUE
100	S	32,800	MC	1.00	100	1.00	100	1.00	R02	1.00		324,480

CLASS	CLASS%	DESCRIPTION			BN ID	BN	CARD	
1010	100	SINGLE FAMILY				1	1 of 1	
PMT NO	PMT DT	TY	DESC	AMOUNT	INSP	BY	1st	%
23-375	05/09/2023	6	Pools etc	98,000				0
23-375	04/14/2023	6	Pools etc	98,000				0
18-311	04/19/2018	3	Renovations	35,500	02/13/2019	TCK	100	100
13-041	01/24/2013	3	Renovations	10,000	04/09/2014	SF	100	100
	02/12/2010	50	Meas & List			RRC	100	100

TOTAL	32,800 SF	ZONING	R60	FRNT	0	ASSESSED	CURRENT	PREVIOUS
Nbhd	MID CHATHAM	NOTE				LAND	324,500	270,400
Inf1	100		BUILDING	577,000	525,000			
Inf2	100		DETACHED	0	0			
			OTHER	0	0			
						<b>TOTAL</b>	<b>901,500</b>	<b>795,400</b>

TY	QUAL	COND	DIM/NOTE	YB	UNITS	ADJ PRICE	RCNLD

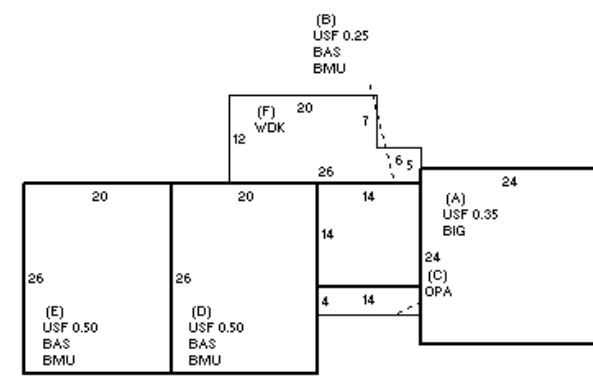

BUILDING	CD	ADJ	DESC	MEASURE	6/1/2017	APK
MODEL	1		RESIDENTIAL	LIST		
STYLE	4	1.00	CAPE [100%]	REVIEW	5/21/2019	TD
QUALITY	A	1.00	AVERAGE [100%]			
FRAME	1	1.00	WOOD FRAME [100%]			

BLDG COMMENTS

YEAR BLT	1984	SIZE ADJ	1.000	ELEMENT	CD	DESCRIPTION	ADJ	S	BAT	T	DESCRIPTION	UNITS	YB	ADJ PRICE	RCN	TOTAL RCN	641,102															
NET AREA	2,007	DETAIL ADJ	1.030	FOUNDATION	4	FLR & WALL	1.00	A	BIG	N	BUILT-IN GARAGE	576		77.17	44,449																	
\$NLA(RCN)	\$319	OVERALL	1.000	EXT. COVER	1	WOOD SHINGLE	1.00	+	USF	L	UP-STRY FIN	771	1984	213.59	164,676																	
				ROOF SHAPE	1	GABLE	1.00	+	BMU	N	BSMT UNFINISHED	1,236		69.18	85,509																	
				ROOF COVER	1	ASPH/CMP SHIN	1.00	+	BAS	L	BAS AREA	1,236	1984	251.71	311,118																	
				FLOOR COVER	24	SOFTWD/ASPH TL	1.00	C	OPA	N	OPEN PORCH	56		76.11	4,262																	
				INT. FINISH	2	DRYWALL	1.00	F	WDK	N	WOOD DECK	270		58.40	15,768																	
				HEATING/COOL	9	WARM/COOL AIR	1.03	F21	O	O	FPL 2S 1OP	1		10,376.00	10,376																	
				FUEL SOURCE	2	GAS	1.00																									
				<table border="1"> <thead> <tr> <th>CONDITION ELEM</th> <th>CD</th> </tr> </thead> <tbody> <tr> <td>EXTERIOR</td> <td>A</td> </tr> <tr> <td>INTERIOR</td> <td>G</td> </tr> <tr> <td>KITCHEN</td> <td>V</td> </tr> <tr> <td>BATHS</td> <td>G</td> </tr> <tr> <td>HEAT</td> <td>U</td> </tr> <tr> <td>ELECT</td> <td>U</td> </tr> </tbody> </table>														CONDITION ELEM	CD	EXTERIOR	A	INTERIOR	G	KITCHEN	V	BATHS	G	HEAT	U	ELECT	U	
CONDITION ELEM	CD																															
EXTERIOR	A																															
INTERIOR	G																															
KITCHEN	V																															
BATHS	G																															
HEAT	U																															
ELECT	U																															
				<table border="1"> <thead> <tr> <th>EFF.YR/AGE</th> <th colspan="2">2012 / 10</th> </tr> </thead> <tbody> <tr> <td>COND</td> <td>10</td> <td>10 %</td> </tr> <tr> <td>FUNC</td> <td>0</td> <td></td> </tr> <tr> <td>ECON</td> <td>0</td> <td></td> </tr> <tr> <td>DEPR</td> <td>10</td> <td>% GD 90</td> </tr> </tbody> </table>														EFF.YR/AGE	2012 / 10		COND	10	10 %	FUNC	0		ECON	0		DEPR	10	% GD 90
EFF.YR/AGE	2012 / 10																															
COND	10	10 %																														
FUNC	0																															
ECON	0																															
DEPR	10	% GD 90																														
				<table border="1"> <thead> <tr> <th>RCNLD</th> <th>\$577,000</th> </tr> </thead> </table>														RCNLD	\$577,000													
RCNLD	\$577,000																															