

Key: 7698

Town of CHATHAM - Fiscal Year 2024

9/7/2023 9:38 am SEQ #: 8.227

LEGAL

CURRENT OWNER				PARCEL ID				LOCATION				
JENKINS D LYNNE 278 GREENWICH AVE GREENWICH, CT 06830-6508				9L-3-3A				105 FOX HILL RD				
TRANSFER HISTORY				DOS	T	SALE PRICE	BK-PG (Cert)					
JENKINS D LYNNE				01/12/2005	A	800,000	19436-221					
JENKINS DORIS L				11/27/2001	A	1	14487-244					
JENKINS				01/14/1994	QS	240,000	9003-312					
CD	T	AC/SF/UN	Nbhd	Inf1	Inf2	ADJ BASE	SAF	Inf3	Lpi	VC	CREDIT AMT	ADJ VALUE
100	S	20,436	NC	1.00	1.00	916,250	1.74	100	1.00	GF1	2.50	749,540

LAND

TOTAL	20,436 SF	ZONING	R40	FRNT	0	ASSESSED	CURRENT	PREVIOUS
Nbhd	NORTH CHATHAM	N O T E	Abuts Eastw-ho Golf GOLF FRONT			LAND	749,500	624,600
Inf1	100		LAND	738,400	650,000			
Inf2	100		OTHER	14,400	13,700			
						OTHER	0	0
						TOTAL	1,502,300	1,288,300

DETACHED

TY	QUAL	COND	DIM/NOTE	YB	UNITS	ADJ PRICE	RCNLD
PTD	A	1.00	70 0.30	1981	120	11.30	400
CBN	A	1.00	30 0.70	1981	432	39.05	11,800
SHF	A	1.00	10 0.90	1997	216	11.55	2,200



PHOTO 04/14/2014

BLDG COMMENTS
BMF=REC.RM

BUILDING

BUILDING	CD	ADJ	DESC	MEASURE		
MODEL	1		RESIDENTIAL	LIST	7/19/2013	SF
STYLE	18	1.30	RENO'D ANTIQUE [100%]	REVIEW	3/3/2017	APK
QUALITY	+	1.20	PLUS AVE [100%]			
FRAME	1	1.00	WOOD FRAME [100%]			

CLASS	CLASS%	DESCRIPTION			BN ID	BN	CARD	
1010	100	SINGLE FAMILY				1	1 of 1	
PMT NO	PMT DT	TY	DESC	AMOUNT	INSP	BY	1st	%
11-144	04/13/2011	61	Inspect/Revi		07/19/2013	SF	100	100
	02/12/2010	2	Additions	50,000	04/14/2014	MR	100	100
	09/01/1997	50	Meas & List			RRC	100	100
97-346	08/06/1997	99	n/a	2,800			100	100
SP 97-53		99	n/a				100	100

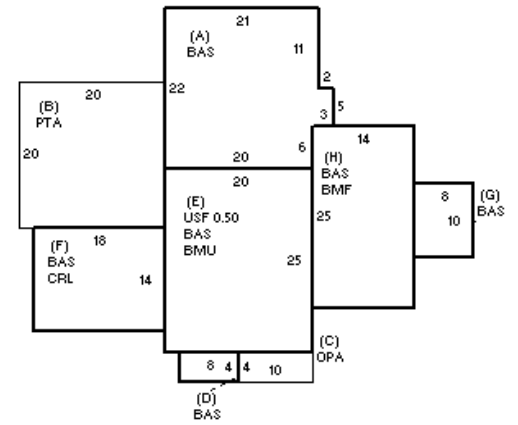

YEAR BLT	1870	SIZE ADJ	1.000	ELEMENT	CD	DESCRIPTION	ADJ
NET AREA	1,930	DETAIL ADJ	1.339	FOUNDATION	4	FLR & WALL	1.00
\$NLA(RCN)	\$461	OVERALL	1.000	EXT. COVER	1	WOOD SHINGLE	1.00
CAPACITY				ROOF SHAPE	1	GABLE	1.00
STORIES	1.5	1.00		ROOF COVER	1	ASPH/CMP SHIN	1.00
ROOMS	6	1.00		FLOOR COVER	36	CARPET/OTHER	1.00
BEDROOMS	3	1.00		INT. FINISH	1	PLASTER	1.00
FULL BATHS	3	1.00		HEATING/COOL	9	WARM/COOL AIR	1.03
1/2 BATHS	1	1.00		FUEL SOURCE	2	GAS	1.00
FIXTURES	12	\$15,425					
UNITS	1	1.00					

S	BAT	T	DESCRIPTION	UNITS	YB	ADJ PRICE	RCN
+	BAS	L	BAS AREA	1,348	1870	395.51	533,147
B	PTA	N	PATIO/STOOP	400		21.48	8,592
C	OPA	N	OPEN PORCH	40		91.32	3,653
E	BMU	N	BSMT UNFINISHED	500		93.46	46,729
E	USF	L	UP-STRY FIN	250	1870	335.60	83,900
F	CRL	N	CRAWL SPACE	252		27.80	7,004
F	BAS	L	BAS AREA	252	1998	395.51	99,668
G	BAS	L	BAS AREA	80	2011	395.51	31,640
H	BMF	N	BSMT FINISH-SEP	350		130.32	45,612
	F21	O	FPL 2S 1OP	1		12,451.20	12,451
	ODS	O	OUT DOOR SHWR-A	1		1,772.40	1,772

TOTAL RCN	889,595
CONDITION ELEM CD	
EXTERIOR	G
INTERIOR	G
KITCHEN	G
BATHS	G
HEAT	U
ELECT	U
EFF.YR/AGE 2005 / 17	
COND	17 17 %
FUNC	0
ECON	0
DEPR	17 % GD 83
RCNLD	\$738,400