

Key: 8364

Town of CHATHAM - Fiscal Year 2024

9/7/2023 9:38 am SEQ #: 8.693

LEG  
AL  
LAND

CURRENT OWNER				PARCEL ID				LOCATION				
FLAHERTY THOMAS & ROBYN 3500 FAIRMOUNT ST APT 622 DALLAS, TX 75219				1A-1A-84				60 SEA MIST LN				
TRANSFER HISTORY				DOS	T	SALE PRICE	BK-PG (Cert)					
FLAHERTY THOMAS & ROBYN				09/21/2016	QS	3,750,000	(210744)					
CALYPSO REALTY TRUST				12/03/2012	A		1 (198862)					
MAGID HERBERT & DEBORAH S				11/16/2007	QS	3,300,000	(184607)					
CD	T	AC/SF/UN	Nbhd	Inf1	Inf2	ADJ BASE	SAF	Inf3	Lpi	VC	CREDIT AMT	ADJ VALUE
100	S	39,924	SC	1.00	100	2,748,750	1.00	100	1.00	WF4	7.50	2,522,580

CLASS	CLASS%	DESCRIPTION			BN ID	BN	CARD	
1010	100	SINGLE FAMILY				1	1 of 1	
PMT NO	PMT DT	TY	DESC	AMOUNT	INSP	BY	1st	%
17-166	03/17/2017	2	Additions	268,527	02/01/2018	APK	100	100
	01/17/2007	51	Meas			RRC	100	100
06-501	09/19/2006	1	New Construc	10,000	01/17/2007		100	100
06-453	08/22/2006	3	Renovations	100,000	01/17/2007		100	100
	01/13/2006	52	Meas & Leave			RRC	100	100

DET  
ACHED

TOTAL	39,924 SF	ZONING	R20	FRNT	0	ASSESSED	CURRENT	PREVIOUS
Nbhd	SOUTH CHATHAM	NOTE great view of ocean with access				LAND	2,522,600	2,102,000
Inf1	100		BUILDING	3,054,600	2,629,300			
Inf2	100		OTHER	4,600	4,400			
						TOTAL	5,581,800	4,735,700

TY	QUAL	COND	DIM/NOTE	YB	UNITS	ADJ PRICE	RCNLD
STR	G	1.20	10 0.90	2006	141	36.00	4,600

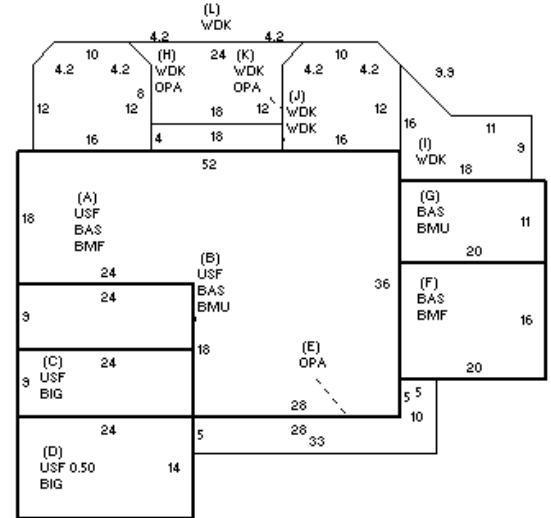

B  
U  
I  
L  
D  
I  
N  
G

BUILDING	CD	ADJ	DESC	MEASURE	2/1/2018	APK
MODEL	1		RESIDENTIAL	LIST		
STYLE	4	1.00	CAPE [100%]	REVIEW	2/1/2018	APK
QUALITY	V	2.35	VERY GOOD [100%]			
FRAME	1	1.00	WOOD FRAME [100%]			

BLDG COMMENTS

YEAR BLT	2007	SIZE ADJ	1.000	ELEMENT	CD	DESCRIPTION	ADJ	S	BAT	T	DESCRIPTION	UNITS	YB	ADJ PRICE	RCN	TOTAL RCN	3,085,475			
NET AREA	4,236	DETAIL ADJ	1.040	FOUNDATION	4	FLR & WALL	1.00	+	BMF	N	BSMT FINISH-SEP	1,760		255.21	449,170	CONDITION ELEM	CD			
\$NLA(RCN)	\$728	OVERALL	1.000	EXT. COVER	1	WOOD SHINGLE	1.00	+	BAS	L	BAS AREA	2,196	2007	542.41	1,191,135	EXTERIOR	G			
				ROOF SHAPE	1	GABLE	1.00	+	USF	L	UP-STRY FIN	2,040	2007	460.25	938,919	INTERIOR	V			
				ROOF COVER	2	WOOD SHIN	1.01	+	BMU	N	BSMT UNFINISHED	436		212.63	92,705	KITCHEN	V			
				FLOOR COVER	1	HARDWOOD	1.00	+	BIG	N	BUILT-IN GARAGE	552		182.16	100,554	BATHS	V			
				INT. FINISH	2	DRYWALL	1.00	+	OPA	N	OPEN PORCH	652		178.83	116,600	HEAT	A			
				HEATING/COOL	9	WARM/COOL AIR	1.03	+	WDK	N	WOOD DECK	1,000		137.24	137,240	ELECT	A			
				FUEL SOURCE	2	GAS	1.00		GFP	O	GAS LOG/FP/E FP	1		14,621.70	14,622					
									ODS	O	OUT DOOR SHWR-A	1		3,471.00	3,471					
																		EFF.YR/AGE	2021 / 1	
																		COND	1 1 %	
																		FUNC	0	
																		ECON	0	
																		DEPR	1 % GD 99	
																		RCNLD	\$3,054,600	