

Key: 844

Town of CHATHAM - Fiscal Year 2024

9/7/2023 9:38 am SEQ #: 930

LEG
AL
LAND

CURRENT OWNER				PARCEL ID				LOCATION				
KLEIN ERIKA L & SCHWARTZ JAMES M MD 9167 TRIVOLI TER NAPLES, FL 34119				11H-20-H85				87 NORTH SKYLINE DR				
TRANSFER HISTORY				DOS	T	SALE PRICE	BK-PG (Cert)					
KLEIN ERIKA L & SCHWARTZ				05/27/2011	QS	640,000	25476-314					
DELOREY MARK J & LYNN VAN				12/19/2001	A	1	14601-105					
DELOREY MARK J				10/17/2001	QS	320,000	14336-252					
CD	T	AC/SF/UN	Nbhd	Inf1	Inf2	ADJ BASE	SAF	Inf3	Lpi	VC	CREDIT AMT	ADJ VALUE
100	S	26,700	MC	1.00	1.00	476,450	1.39	100	1.00	PV2	1.30	407,130

CLASS	CLASS%	DESCRIPTION			BN ID	BN	CARD	
1010	100	SINGLE FAMILY				1	1 of 1	
PMT NO	PMT DT	TY	DESC	AMOUNT	INSP	BY	1st	%
15-629	10/22/2015	3	Renovations	28,150	05/26/2016	WFF	100	100
06-686	04/02/2007	50	Meas & List	18,000		RRC	100	100
	12/21/2006	2	Additions			100	100	
P2001130	03/11/2002	50	Meas & List			JB	100	100
	07/02/2001	99	n/a				100	100

DET
ACHED

TOTAL	26,700 SF	ZONING	R60	FRNT	0	ASSESSED	CURRENT	PREVIOUS
Nbhd	MID CHATHAM	N O T E	AVG PONDVIEW SEASONAL, DEEDED RIGHTS TO LOVERS LAKE			LAND	407,100	391,500
Inf1	100		BUILDING	619,900	564,100			
Inf2	100		OTHER	0	0			
			TOTAL	1,027,000	955,600			

TY	QUAL	COND	DIM/NOTE	YB	UNITS	ADJ PRICE	RCNLD



BLDG COMMENTS

LLF=3RMS, 1F.BATH

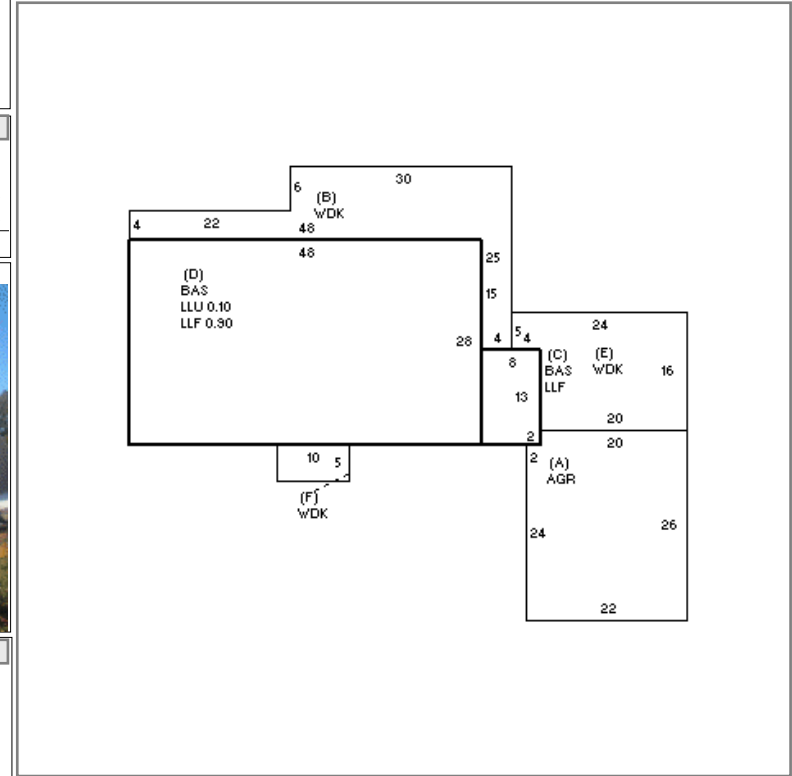

B
U
I
L
D
I
N
G

BUILDING	CD	ADJ	DESC	MEASURE	11/16/2021	NF
MODEL	1		RESIDENTIAL	LIST	11/16/2021	EST
STYLE	1	0.85	RANCH [100%]	REVIEW	12/14/2021	MR
QUALITY	+	1.20	PLUS AVE [100%]			
FRAME	1	1.00	WOOD FRAME [100%]			

YEAR BLT	1973	SIZE ADJ	1.000	ELEMENT	CD	DESCRIPTION	ADJ	S	BAT	T	DESCRIPTION	UNITS	YB	ADJ PRICE	RCN	TOTAL RCN	737,939		
NET AREA	1,448	DETAIL ADJ	0.875	FOUNDATION	4	FLR & WALL	1.00	A	AGR	N	ATTACHED GARAGE	568		92.71	52,657	CONDITION ELEM	CD		
\$NLA(RCN)	\$510	OVERALL	1.000	EXT. COVER	4	VINYL	1.00	+	WDK	N	WOOD DECK	838		70.08	58,727	EXTERIOR	G		
				ROOF SHAPE	1	GABLE	1.00	+	LLF	N	LOWER LEVEL FIN	1,314		178.71	234,818	INTERIOR	G		
				ROOF COVER	1	ASPH/CMP SHIN	1.00	+	BAS	L	BAS AREA	1,448	1973	242.83	351,619	KITCHEN	G		
				FLOOR COVER	14	HARDWD/ASPH TL	1.00	D	LLU	N	LOWER LEVEL UN	134		136.82	18,334	BATHS	V		
				INT. FINISH	23	DRYWLI/WD PNL	1.00		F12	O	FPL 1S 2OP	1		12,451.20	12,451	BATHS	V		
				HEATING/COOL	9	WARM/COOL AIR	1.03		ODS	O	OUT DOOR SHWR-A	1		1,772.40	1,772	HEAT	A		
				FUEL SOURCE	1	OIL	1.00									ELECT	U		
																		EFF.YR/AGE	2006 / 16
																		COND	16 16 %
																		FUNC	0
																		ECON	0
																		DEPR	16 % GD 84
																		RCNLD	\$619,900