

Key: 8533

Town of CHATHAM - Fiscal Year 2024

9/7/2023 9:38 am SEQ #: 8.851

LEGALS

CURRENT OWNER						PARCEL ID				LOCATION			
NOVIEW REALTY TRUST COLECCHI MICHAEL L & CAROL A TRSTES 23 SEACREST VILLAGE LN CHATHAM, MA 02633						10E-51J-XW2				23 SEACREST VILLAGE LN			
TRANSFER HISTORY						DOS	T	SALE PRICE	BK-PG (Cert)				
NOVIEW REALTY TRUST						12/11/2017	QS	962,500	30954-249				
KULHAWIK EDWARD V JR & SEACREST VILLAGE LLC						05/14/2012	QS	649,000	26327-257				
						06/08/2011	B	10	25498-5				

CLASS	CLASS%	DESCRIPTION			BN ID	BN	CARD	
1020	100	CONDOMINIUM				1	1 of 1	
PMT NO	PMT DT	TY	DESC	AMOUNT	INSP	BY	1st	%
11-393	04/18/2018	98	SALES QUESTI					0
	04/18/2018	98	SALES QUESTI					0
	05/11/2012	50	Meas & List		05/11/2012	MR	100	100
11-191	10/11/2011	1	New Construc	200,000	06/17/2013	SF	100	100
	05/13/2011	9	Foundation	7,200	05/11/2012	MR	100	100

LAND

CD	T	AC/SF/UN	Nbhd	Inf1	Inf2	ADJ BASE	SAF	Inf3	Lpi	VC	CREDIT AMT	ADJ VALUE

TOTAL	SF	ZONING	R20	FRNT	0	ASSESSED	CURRENT	PREVIOUS
Nbhd		NOTE	mixed use, also GB3-10,000sf			LAND	0	0
Inf1					BUILDING	1,082,700	968,400	
Inf2					DETACHED	0	0	
					OTHER	0	0	
					TOTAL	1,082,700	968,400	

DETACHED

TY	QUAL	COND	DIM/NOTE	YB	UNITS	ADJ PRICE	RCNLD	PHOTO
								06/17/2013

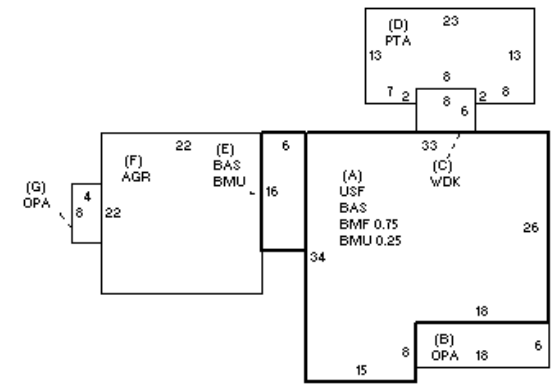

BLDG COMMENTS

BUILDING

BUILDING	CD	ADJ	DESC	MEASURE	5/11/2012	MR
MODEL	10		CONDO	LIST	5/11/2012	MR
STYLE	2	1.00	FREE STANDING [100%]	REVIEW	10/22/2018	APK
QUALITY	G	1.20	GOOD [100%]			
FRAME	99	1.00	N/A [100%]			

BUILDING

YEAR BLT	2011	SIZE ADJ	1.000	ELEMENT	CD	DESCRIPTION	ADJ
NET AREA	2,052	DETAIL ADJ	1.854	COMPLEX	90	MONOMOY V-FS	1.80
\$NLA(RCN)	\$544	OVERALL	1.000	UNIT MODEL	99	N/A	1.00
				VIEW/LOC	1	NONE	1.00
				HVAC	9	WARM/COOL AIR	1.03
				FUEL SOURCE	2	GAS	1.00
				FLOOR LEVEL	99	N/A	1.00
				NEIGHBORHOOD	1	MID-CHATHAM	1.00

S	BAT	T	DESCRIPTION	UNITS	YB	ADJ PRICE	RCN
+	BMU	N	BSMT UNFINISHED	341		23.00	7,843
A	BMF	N	BSMT FINISH-SEP	734		36.10	26,497
+	BAS	L	BAS AREA	1,074	2011	515.27	553,402
A	USF	L	UP-STRY FIN	978	2011	489.55	478,784
+	OPA	N	OPEN PORCH	140		24.90	3,486
C	WDK	N	ATT WOOD DECK	48		19.00	912
D	PTA	N	PATIO	283		5.70	1,613
F	AGR	N	ATTACHED GARAGE	484		47.50	22,989
	GFP	O	GAS LOG/FP/E FP	1		2,846.00	2,846

TOTAL RCN	1,116,172
CONDITION ELEM CD	
INTERIOR	A
KITCHEN	A
BATHS	A
EXTERIOR	A
EFF.YR/AGE	2011 / 11
COND	3 3 %
FUNC	0
ECON	0
DEPR	3 % GD 97
RCNLD	\$1,082,700