

Key: 892

Town of CHATHAM - Fiscal Year 2024

9/7/2023 9:38 am SEQ #: 979

LEGAL

LAND

DETACHED

BUILDING

CURRENT OWNER				PARCEL ID				LOCATION				
FIERY JR RICHARD D & MARGARET E 202 N SKYLINE DR CHATHAM, MA 02633				11H-9-H71				202 NORTH SKYLINE DR				
TRANSFER HISTORY				DOS	T	SALE PRICE	BK-PG (Cert)					
FIERY JR RICHARD D & MARG				01/15/2021	QS	2,150,000	33690-41					
QUINN PHILIP B & SUSAN A				05/28/2004	D	1,550,000	18657-339					
MARSH WILLIAM TRUSTEE				10/02/2002	N	1,100,000	15684-163					
CD	T	AC/SF/UN	Nbhd	Inf1	Inf2	ADJ BASE	SAF	Inf3	Lpi	VC	CREDIT AMT	ADJ VALUE
100	S	34,200	MC	1.00	100	1.00	100	1.00	1.14	100	1.00	523,100

CLASS	CLASS%	DESCRIPTION			BN ID	BN	CARD
1010	100	SINGLE FAMILY				1	1 of 1
PMT NO	PMT DT	TY	DESC	AMOUNT	INSP	BY	1st %
G22-805	12/27/2022	99	n/a				100 100
	03/26/2021	98	SALES QUESTI				100 100
	03/01/2005	50	Meas & List			RRC	100 100
03-319	07/14/2003	2	Additions	2,000			100 100
P2003319	05/28/2003	2	Additions	14,725			100 100

TOTAL	34,200 SF	ZONING	R60	FRNT	0	ASSESSED	CURRENT	PREVIOUS
Nbhd	MID CHATHAM	NOTE Vw DISTANT WITH SOME OBSTR			LAND	523,100	435,900	
Inf1	100		BUILDING	2,016,700	1,798,600			
Inf2	100		OTHER	0	0			
TOTAL						2,539,800	2,234,500	

TY	QUAL	COND	DIM/NOTE	YB	UNITS	ADJ PRICE	RCNLD



BUILDING	CD	ADJ	DESC	MEASURE	11/16/2021	NF
MODEL	1		RESIDENTIAL	LIST	11/16/2021	EST
STYLE	19	1.30	NEW STYLE [100%]	REVIEW	5/16/2022	MR
QUALITY	G	1.55	GOOD [100%]			
FRAME	1	1.00	WOOD FRAME [100%]			

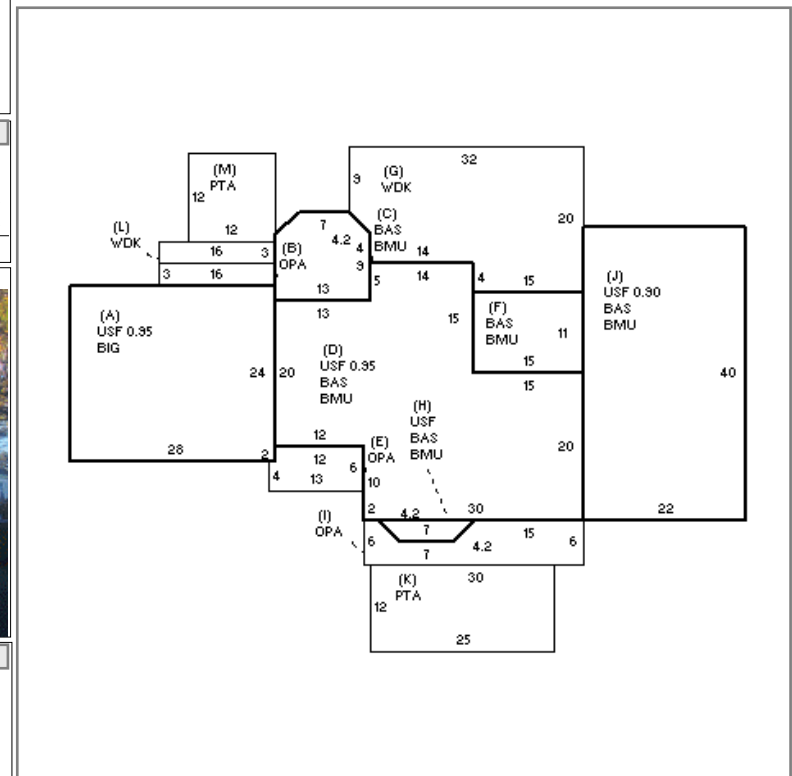

YEAR BLT	2004	SIZE ADJ	1.000	ELEMENT	CD	DESCRIPTION	ADJ	S	BAT	T	DESCRIPTION	UNITS	YB	ADJ PRICE	RCN	TOTAL RCN	2,459,449		
NET AREA	4,749	DETAIL ADJ	1.339	FOUNDATION	4	FLR & WALL	1.00	A	BIG	N	BUILT-IN GARAGE	672		117.86	79,202	CONDITION ELEM	CD		
\$NLA(RCN)	\$518	OVERALL	1.000	EXT. COVER	1	WOOD SHINGLE	1.00	+	USF	L	UP-STRY FIN	2,467	2004	387.30	955,459	EXTERIOR	A		
				ROOF SHAPE	1	GABLE	1.00	+	OPA	N	OPEN PORCH	274		117.95	32,319	INTERIOR	A		
				ROOF COVER	1	ASPH/CMP SHIN	1.00	+	BMU	N	BSMT UNFINISHED	2,282		97.63	222,796	KITCHEN	A		
				FLOOR COVER	16	HARDWD/OTHER	1.00	+	BAS	L	BAS AREA	2,282	2004	456.43	1,041,572	BATHS	A		
				INT. FINISH	2	DRYWALL	1.00	+	WDK	N	WOOD DECK	604		90.52	54,675	HEAT	A		
				HEATING/COOL	9	WARM/COOL AIR	1.03	+	PTA	N	PATIO/STOOP	444		27.75	12,319	ELECT	A		
				FUEL SOURCE	2	GAS	1.00		GEN	O	GENERATOR	1		0.00					
													GFP	O	GAS LOG/FP/E FP	3	9,643.60	28,931	
													ODS	O	OUT DOOR SHWR-A	1	2,289.40	2,289	
													EFF.YR/AGE		2004 / 18				
													COND	18	18 %				
													FUNC	0					
													ECON	0					
													DEPR	18	% GD	82			
													RCNLD				\$2,016,700		