

Key: 931

Town of CHATHAM - Fiscal Year 2024

9/7/2023 9:38 am SEQ #: 1.018

LEGAL

LAND

DETACHED

BUILDING

CURRENT OWNER				PARCEL ID				LOCATION			
SCHAIN ROBERT L & DEBORAH B PO BOX 453 CHATHAM, MA 02633-0453				111-43-G31				15 LORDS POND LN			
TRANSFER HISTORY				DOS	T	SALE PRICE	BK-PG (Cert)				
SCHAIN ROBERT L & DEBORAH				05/01/2006	QS	600,000	20963-208				
BUCKLEY ROBERT W & JANET				05/01/1984	QS	31,000	4099-271				

CLASS	CLASS%	DESCRIPTION			BN ID	BN	CARD	
1010	100	SINGLE FAMILY				1	1 of 1	
PMT NO	PMT DT	TY	DESC	AMOUNT	INSP	BY	1st	%
17-205	03/27/2017	11	Window Rplc		06/27/2018	NF	100	100
	04/02/2007	50	Meas & List			RRC	100	100
05-436	09/16/2005	10	Reroof	9,000			100	100
	04/01/2003	50	Meas & List			JB	100	100
P2002582	11/20/2002	14	DECK	7,500			100	100

CD	T	AC/SF/UN	Nbhd	Inf1	Inf2	ADJ BASE	SAF	Inf3	Lpi	VC	CREDIT AMT	ADJ VALUE
100	S	30,640	MC	1.00	100	1.00	100	1.00	R03	1.00		320,650

TOTAL	30,640 SF	ZONING	R60	FRNT	0	ASSESSED	CURRENT	PREVIOUS
Nbhd	MID CHATHAM	NOTE HOUSE FACES OLD COMERS/DEEDED RIGHT TO LOVERS LAKE			LAND	320,700	267,200	
Inf1	100		BUILDING	475,000	432,200			
Inf2	100		DETACHED	1,000	900			
			OTHER	0	0			
TOTAL						796,700	700,300	

TY	QUAL	COND	DIM/NOTE	YB	UNITS	ADJ PRICE	RCNLD
SHF	A	1.00	20 0.80 10X8		80	15.24	1,000

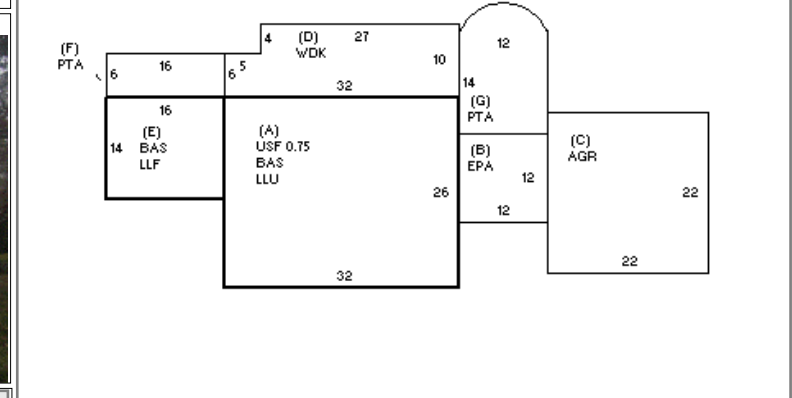

BUILDING	CD	ADJ	DESC	MEASURE	12/15/2021	NF
MODEL	1		RESIDENTIAL	LIST	12/15/2021	EST
STYLE	5	1.00	COLONIAL [100%]	REVIEW	1/24/2022	EMZ
QUALITY	A	1.00	AVERAGE [100%]			
FRAME	1	1.00	WOOD FRAME [100%]			

BLDG COMMENTS

YEAR BLT	1984	SIZE ADJ	1.000	ELEMENT	CD	DESCRIPTION	ADJ	S	BAT	T	DESCRIPTION	UNITS	YB	ADJ PRICE	RCN	TOTAL RCN	633,329	
NET AREA	1,680	DETAIL ADJ	1.040	FOUNDATION	4	FLR & WALL	1.00	A	LLU	N	LOWER LEVEL UN	832		136.55	113,612	CONDITION ELEM	CD	
\$NLA(RCN)	\$377	OVERALL	1.000	EXT. COVER	1	WOOD SHINGLE	1.00	A	BAS	L	BAS AREA	832	1984	242.35	201,639	EXTERIOR	A	
				ROOF SHAPE	6	SALTBOX	1.00	A	USF	L	UP-STRY FIN	624	1984	205.65	128,323	INTERIOR	A	
				ROOF COVER	2	WOOD SHIN	1.01	B	EPA	N	ENCL PORCH	144		133.70	19,253	KITCHEN	A	
				FLOOR COVER	13	HARDWD/CARPET	1.00	C	AGR	N	ATTACHED GARAGE	484		78.56	38,024	BATHS	A	
				INT. FINISH	2	DRYWALL	1.00	D	WDK	N	WOOD DECK	300		58.40	17,520	HEAT	A	
				HEATING/COOL	9	WARM/COOL AIR	1.03	E	LLF	N	LOWER LEVEL FIN	224		178.35	39,951	ELECT	A	
				FUEL SOURCE	2	GAS	1.00	E	BAS	L	BAS AREA	224	2001	242.35	54,287			
									+	PTA	N	PATIO/STOOP	299		17.90	5,352		
										F21	O	FPL 2S 1OP	1		10,376.00	10,376		
										GEN	O	GENERATOR	1		0.00			
														EFF.YR/AGE	1988 / 34			
														COND	25	25%		
														FUNC	0			
														ECON	0			
														DEPR	25	% GD	75	
														RCNLD			\$475,000	