

Key: 990

Town of CHATHAM - Fiscal Year 2024

9/7/2023 9:38 am SEQ #: 1.085

LEGALS

CURRENT OWNER				PARCEL ID				LOCATION				
INFANTINO ROBERT J 54 WINDSOR RD WABAN, MA 02468-1505				11K-33-HC11				129 SEAPINE RD				
TRANSFER HISTORY				DOS	T	SALE PRICE	BK-PG (Cert)					
INFANTINO ROBERT J				06/15/2004	QS	2,650,000	(173359)					
HANNA HARRY ESTATE				09/14/1999	A	1	(154751)					
HANNA HAZEL ESTATE				11/21/1951	N	1	(13395)					
CD	T	AC/SF/UN	Nbhd	Inf1	Inf2	ADJ BASE	SAF	Inf3	Lpi	VC	CREDIT AMT	ADJ VALUE
100	S	34,375	NC	1.00	100	2,382,250	1.13	100	1.00	CFC	6.50	2,126,960

CLASS	CLASS%	DESCRIPTION			BN ID	BN	CARD	
1010	100	SINGLE FAMILY				1	1 of 2	
PMT NO	PMT DT	TY	DESC	AMOUNT	INSP	BY	1st	%
05-385	04/12/2006	50	Meas & List			RRC	100	100
	08/29/2005	2	Additions	800,000	04/12/2006		100	100
	07/07/2005	50	Meas & List			JB	100	100
95-423	12/01/1995	3	Renovations	15,750	07/07/2005		100	100
1995386	11/20/1995	99	n/a				100	100

LAND

TOTAL	34,375 SF	ZONING	R40	FRNT	0	ASSESSED	CURRENT	PREVIOUS
Nbhd	NORTH CHATHAM	NOTE CROWS PONDFRONT	LAND	2,127,000	1,772,400			
Inf1	100		BUILDING	1,977,900	1,706,300			
Inf2	100		DETACHED	0	0			
			OTHER	82,900	78,000			
TOTAL			4,187,800	3,556,700				

DETACHED

TY	QUAL	COND	DIM/NOTE	YB	UNITS	ADJ PRICE	RCNLD



BLDG COMMENTS

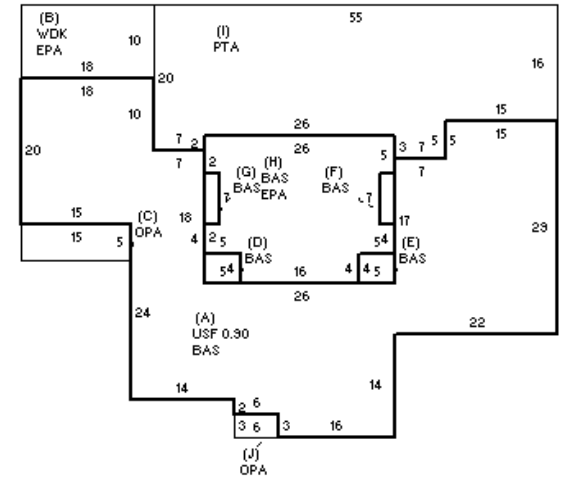

BUILDING

BUILDING	CD	ADJ	DESC	MEASURE	REVIEW
MODEL	1		RESIDENTIAL		
STYLE	4	1.00	CAPE [100%]	LIST	
QUALITY	V	2.35	VERY GOOD [100%]	REVIEW	1/9/2013 MR
FRAME	1	1.00	WOOD FRAME [100%]		

LOADING

YEAR BLT	1954	SIZE ADJ	1.000	ELEMENT	CD	DESCRIPTION	ADJ	S	BAT	T	DESCRIPTION	UNITS	YB	ADJ PRICE	RCN	TOTAL RCN	2,472,398				
NET AREA	3,904	DETAIL ADJ	1.050	FOUNDATION	4	FLR & WALL	1.00	+	BAS	L	BAS AREA	1,829	1954	551.98	1,009,577	CONDITION ELEM	CD				
\$NLA(RCN)	\$633	OVERALL	1.000	EXT. COVER	1	WOOD SHINGLE	1.00	A	USF	L	UP-STRY FIN	1,603	1954	468.38	750,806	EXTERIOR					
				ROOF SHAPE	3	GAMBREL	1.00	+	EPA	N	ENCL PORCH	632		314.19	198,570	INTERIOR					
				ROOF COVER	1	ASPH/CMP SHIN	1.00	B	WDK	N	WOOD DECK	180		137.24	24,703	KITCHEN					
				FLOOR COVER	1	HARDWOOD	1.00	+	OPA	N	OPEN PORCH	93		178.83	16,631	BATHS					
				INT. FINISH	2	DRYWALL	1.00	+	BAS	L	BAS AREA	472	1954	551.98	260,535	HEAT					
				HEATING/COOL	11	HT-WT/COOL AIR	1.05	I	PTA	N	PATIO/STOOP	995		42.07	41,856	ELECT					
				FUEL SOURCE	2	GAS	1.00	BMU	N	BSMT UNFINISHED	525		205.60	107,938							
												F22	O	FPL 2S 2OP	1	34,145.50	34,146				
CAPACITY		UNITS	ADJ															EFF.YR/AGE	2002 / 20		
STORIES		1.9	1.00															COND	20 20 %		
ROOMS		0	1.00															FUNC	0		
BEDROOMS		4	1.00															ECON	0		
FULL BATHS		4	1.00															DEPR	20	% GD	80
1/2 BATHS		1	1.00															RCNLD	\$1,977,900		
FIXTURES		14	\$27,636																		
UNITS		1	1.00																		

Key: 990

Town of CHATHAM - Fiscal Year 2024

9/7/2023 9:38 am SEQ #: 1.086

LEGAL

CURRENT OWNER			PARCEL ID			LOCATION		
INFANTINO ROBERT J 54 WINDSOR RD WABAN, MA 02468-1505			11K-33-HC11			129 SEAPINE RD		
TRANSFER HISTORY			DOS	T	SALE PRICE	BK-PG (Cert)		

CLASS	CLASS%	DESCRIPTION			BN ID	BN	CARD	
1010	100	SINGLE FAMILY				2	2 of 2	
PMT NO	PMT DT	TY	DESC	AMOUNT	INSP	BY	1st	%

LAND

CD	T	AC/SF/UN	Nbhd	Inf1	Inf2	ADJ BASE	SAF	Inf3	Lpi	VC	CREDIT AMT	ADJ VALUE
----	---	----------	------	------	------	----------	-----	------	-----	----	------------	-----------

TOTAL	ZONING	FRNT	ASSESSED	CURRENT	PREVIOUS
Nbhd	NOTE		LAND	82,900	
Inf1		BUILDING			
Inf2		DETACHED			
			OTHER		
			TOTAL		

DETACHED

TY	QUAL	COND	DIM/NOTE	YB	UNITS	ADJ PRICE	RCNLD
----	------	------	----------	----	-------	-----------	-------

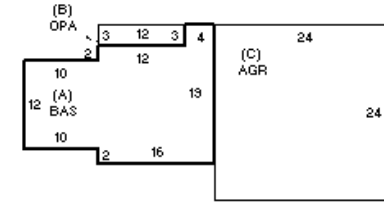

BUILDING

BUILDING	CD	ADJ	DESC	MEASURE		
MODEL	1		RESIDENTIAL	LIST		
STYLE	17	0.95	GAR/APT [100%]	REVIEW	1/9/2013	MR
QUALITY	A	1.00	AVERAGE [100%]			
FRAME	1	1.00	WOOD FRAME [100%]			

BLDG COMMENTS
NO KITCHEN PER MLS

G

YEAR BLT	1954	SIZE ADJ	1.000	ELEMENT	CD	DESCRIPTION	ADJ	S	BAT	T	DESCRIPTION	UNITS	YB	ADJ PRICE	RCN	TOTAL RCN	142,959		
NET AREA	388	DETAIL ADJ	0.691	FOUNDATION	2	SLAB	0.95	A	BAS	L	BAS AREA	388	1954	243.98	94,664	CONDITION ELEM	CD		
\$NLA(RCN)	\$368	OVERALL	1.000	EXT. COVER	1	WOOD SHINGLE	1.00	B	OPA	N	OPEN PORCH	36		76.11	2,740	EXTERIOR			
				ROOF SHAPE	1	GABLE	1.00	C	AGR	N	ATTACHED GARAGE	576		77.17	44,449	INTERIOR			
				ROOF COVER	2	WOOD SHIN	1.01									KITCHEN			
				FLOOR COVER	8	MINIMUM	1.00									BATHS			
				INT. FINISH	6	MINIMUM	0.95									HEAT			
				HEATING/COOL	13	NONE	0.80									ELECT			
				FUEL SOURCE	8	NONE	1.00												
																		EFF.YR/AGE	1965 / 57
																		COND	42 42 %
																		FUNC	0
																		ECON	0
																		DEPR	42 % GD 58
																		RCNLD	\$82,900