

CURRENT OWNER		TOPO	UTILITIES	STRT / ROAD	LOCATION	CURRENT ASSESSMENT				
LYONS WILLIAM E			0 Water	0 Feeder	0 Average	Description	Code	Appraised	Assessed	905 DUXBURY, MA
LYONS MEGHAN B B			0 No Sewer	0 Paved	0 Average	RESIDNTL	1010	400,000	400,000	
144 LAKE SHORE DR		SUPPLEMENTAL DATA			RES LAND	1010	389,100	389,100		
DUXBURY MA 02332		Alt Prcl ID Scnd Home Tax Class T Tot Fin Area 2311 Total Acres .966 Chapter Lan GIS ID F_856722_2836838			Cyclical 2 Exemption W District Res Exem Assoc Pid#	RESIDNTL	1010	2,900	2,900	
						Total		792,000	792,000	

VISION

RECORD OF OWNERSHIP		BK-VOL/PAGE	SALE DATE	Q/U	V/I	SALE PRICE	VC	PREVIOUS ASSESSMENTS (HISTORY)								
LYONS WILLIAM E		16426 0146	07-22-1998	Q	I	246,000	00	Year	Code	Assessed	Year	Code	Assessed	Year	Code	Assessed
CLINTON DENISE MCGANN TR		13863 0005	09-29-1995	U	I	178,000	1A	2023	1010	298,200	2022	1010	248,600	2021	1010	260,100
MCGANN DENIS J		12821 0018	04-21-1994	U	I	184,000	1A		1010	346,700		1010	311,900		1010	253,900
									1010	2,100		1010	2,100		1010	2,100
						Total		647,000	Total		562,600	Total		516,100		

EXEMPTIONS			OTHER ASSESSMENTS					
Year	Code	Description	Amount	Code	Description	Number	Amount	Comm Int
		Total	0.00					

This signature acknowledges a visit by a Data Collector or Assessor

APPRAISED VALUE SUMMARY			
Appraised Bldg. Value (Card)			400,000
Appraised Xf (B) Value (Bldg)			0
Appraised Ob (B) Value (Bldg)			2,900
Appraised Land Value (Bldg)			389,100
Special Land Value			0
Total Appraised Parcel Value			792,000
Valuation Method			C
Total Appraised Parcel Value			792,000

ASSESSING NEIGHBORHOOD				
Nbhd	Nbhd Name	B	Tracing	Batch
0030				

NOTES							
MAIN PART W FULL REAR DRMR-SALTBOX-LIKE							

BUILDING PERMIT RECORD								VISIT / CHANGE HISTORY						
Permit Id	Issue Date	Type	Description	Amount	Insp Date	% Comp	Date Comp	Comments	Date	Id	Type	Is	Cd	Purpose/Result
BPO-21-467	11-03-2021	MN	Maintenance	5,000		100	11-03-2021	WEATHERIZATION/INSULATIO	09-13-2018	JLF			20	Field Review
									04-12-2013	VGS			20	Field Review
									05-19-2007	BSB		1	00	Measure & Listed

LAND LINE VALUATION SECTION															
B	Use Code	Description	Zone	Land Type	Land Units	Unit Price	Size Adj	Site Index	Cond.	Nbhd.	Nbhd. Adj	Notes	Location Adjustment	Adj Unit P	Land Value
1	1010	Single Family	RC	Primary	40,000 SF	8.75	1.00000	5	1.00	0030	0.886		V125	1.2500	387,600
1	1010	Single Family	WP	Residual	0.048 AC	35,000.00	1.00000	5	1.00	0030	0.886		1.0000	0.71	1,500
Total Card Land Units					0.97 AC	Parcel Total Land Area					0.97	Total Land Value			389,100

CONSTRUCTION DETAIL			CONSTRUCTION DETAIL (CONTINUED)		
Element	Cd	Description	Element	Cd	Description
Style	04	Cape Cod	Bsmt Area	1296	
Model	01	Residential	Bsmt Type	04	
Grade	05	Ave/Good	Unfin Area	0.00	Full
Stories	1.75				
Occupancy	1				
Exterior Wall 1	14	Wood Shingle			
Exterior Wall 2	11	Clapboard			
Roof Structure	03	Gable			
Roof Cover	03	Asphalt			
Interior Wall 1	05	Drywall			
Interior Wall 2					
Interior Floor 1	12	Hardwood			
Interior Floor 2					
Heat Fuel	03	Gas			
Heat Type	05	Hot Water			
AC Type	01	None			
Bedrooms	4				
Full Baths	2				
Half Baths	1				
Extra Fixtures	0				
Total Rooms	7				
Bath Style	02	Average			
Kitchen Style	02	Average			
Extra Kitchens	0				
Fireplaces	1				
Extra Openings	0				
Gas Fireplaces	0				
Sq Ft Fin Bsmt	0				
FBM Quality					
Foundation	06	Poured Conc			
Bsmt Garage	0				
Bsmt Area	1296				

CONDO DATA			
Parcel Id		C	Own
		B	S
Adjust Type	Code	Description	Factor%
Condo Flr			
Condo Unit			

COST / MARKET VALUATION	
Net Other Adj	506,145
Replace Cost	20,150
Year Built	526,295
Effective Year Built	1987
Depreciation Code	1997
Remodel Rating	A
Year Remodeled	
Depreciation %	24
Functional Obsol	
External Obsol	
Trend Factor	1.000
Condition	
Condition %	
Percent Good	76
Cns Sect Rcnld	400,000
Dep % Ovr	
Dep Ovr Comment	
Misc Imp Ovr	
Misc Imp Ovr Comment	
Cost to Cure Ovr	
Cost to Cure Ovr Comment	

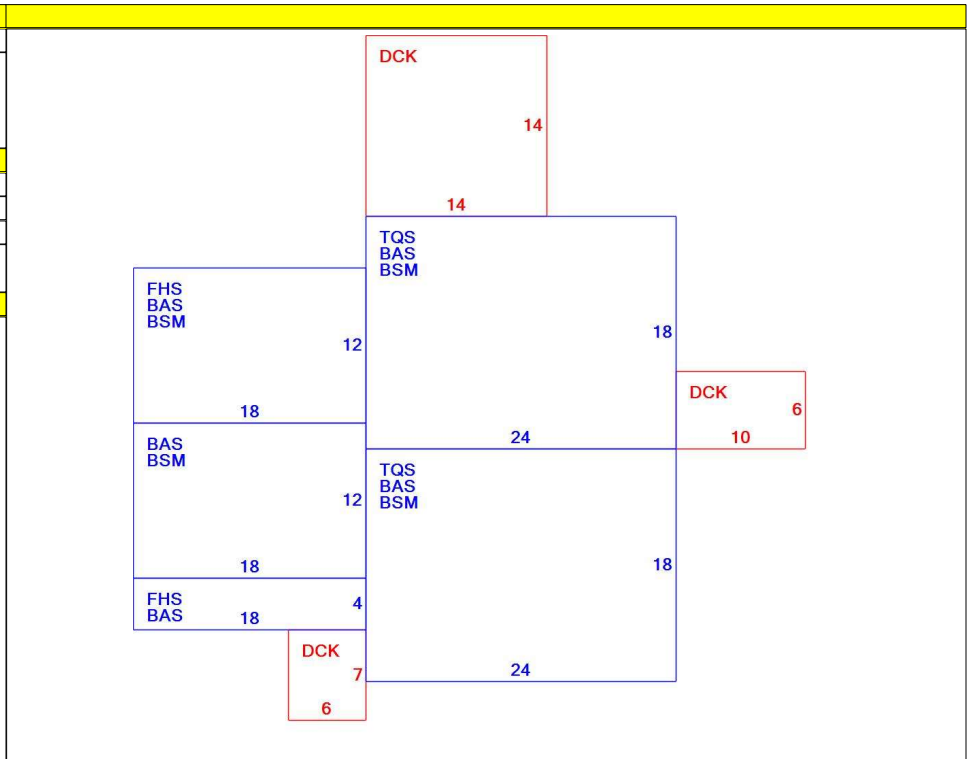

OB - OUTBUILDING & YARD ITEMS(L) / XF - BUILDING EXTRA FEATURES(B)										
Code	Description	L/B	Units	Unit Price	Yr Blt	Cond. Cd	% Gd	Grade	Grade Adj.	Appr. Value
FN2	Fence - Wood	L	120	35.00	1997	A	70	C	1.00	2,900

BUILDING SUB-AREA SUMMARY SECTION						
Code	Description	Living Area	Floor Area	Eff Area	Unit Cost	Undeprec Value
BAS	First Floor	1,368	1,368	1,368	206.67	282,730
BSM	Basement	0	1,296	259	41.30	53,529
DCK	Deck	0	298	30	20.81	6,200
FHS	Finished Half Story	144	288	144	103.34	29,761
TQS	Three Quarter Story	648	864	648	155.01	133,925
Ttl Gross Liv / Lease Area		2,160	4,114	2,449		506,145



144 LAKE SHORE DR

