

CONSTRUCTION DETAIL			CONSTRUCTION DETAIL (CONTINUED)		
Element	Cd	Description	Element	Cd	Description
Style	04	Cape Cod	Bsmt Area	1194	
Model	01	Residential	Bsmt Type	03	
Grade	05	Ave/Good	Unfin Area	0.00	Partial
Stories	1.8				
Occupancy	1		CONDO DATA		
Exterior Wall 1	14	Wood Shingle	Parcel Id		C
Exterior Wall 2					B
Roof Structure	03	Gable	Adjust Type	Code	Description
Roof Cover	03	Asphalt	Condo Flr		Factor%
Interior Wall 1	05	Drywall	Condo Unit		
Interior Wall 2			COST / MARKET VALUATION		
Interior Floor 1	12	Hardwood	Net Other Adj		600,132
Interior Floor 2			Replace Cost		50,700
Heat Fuel	02	Oil	Year Built		650,832
Heat Type	05	Hot Water	Effective Year Built		1977
AC Type	01	None	Depreciation Code		2000
Bedrooms	3		Remodel Rating		G
Full Baths	4		Year Remodeled		
Half Baths	0		Depreciation %		21
Extra Fixtures	0		Functional Obsol		
Total Rooms	7		External Obsol		
Bath Style	02	Average	Trend Factor		1.000
Kitchen Style	02	Average	Condition		
Extra Kitchens	0		Condition %		
Fireplaces	1		Percent Good		79
Extra Openings	0		Cns Sect Rcnld		514,200
Gas Fireplaces	0		Dep % Ovr		
Sq Ft Fin Bsmt	800		Dep Ovr Comment		
FBM Quality	03	Average	Misc Imp Ovr		
Foundation	06	Poured Conc	Misc Imp Ovr Comment		
Bsmt Garage	0		Cost to Cure Ovr		
Bsmt Area	1194		Cost to Cure Ovr Comment		

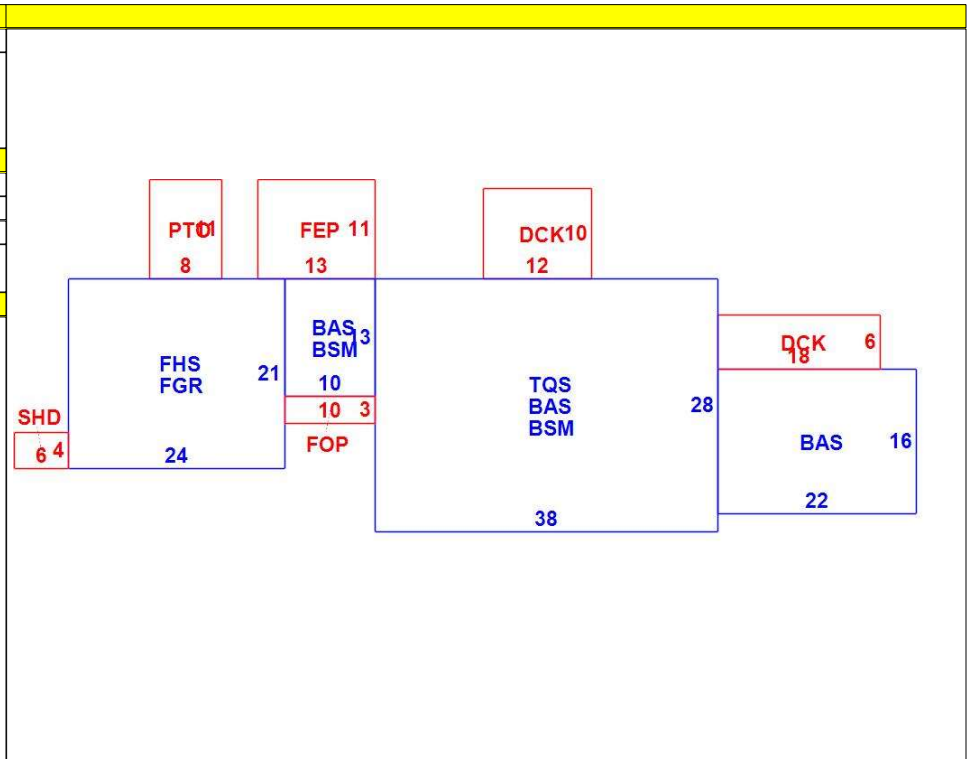

OB - OUTBUILDING & YARD ITEMS(L) / XF - BUILDING EXTRA FEATURES(B)										
Code	Description	L/B	Units	Unit Price	Yr Blt	Cond. Cd	% Gd	Grade	Grade Adj.	Appr. Value
SPL1	Ing Pool - Ave	L	648	64.00	1985	A	70	C	1.00	29,000
SHD1	Shed	L	144	21.00	1985	A	70	C	1.00	2,100
GNR	GENERATOR	L	1	12400.00	2018	E	100	C	1.00	12,400

BUILDING SUB-AREA SUMMARY SECTION						
Code	Description	Living Area	Floor Area	Eff Area	Unit Cost	Undeprec Value
BAS	First Floor	1,546	1,546	1,546	189.74	293,330
BSM	Basement	0	1,194	239	37.98	45,347
DCK	Deck	0	228	23	19.14	4,364
FEP	Finished Enclosed Porch	0	143	86	114.11	16,317
FGR	Garage	0	504	202	76.04	38,326
FHS	Finished Half Story	252	504	252	94.87	47,813
FOP	Open Porch	0	30	5	31.62	949
PTO	Patio	0	88	4	8.62	759
SHD	Attached Shed	0	24	8	63.24	1,518
TQS	Three Quarter Story	798	1,064	798	142.30	151,409
Ttl Gross Liv / Lease Area		2,596	5,325	3,163		600,132

