

CURRENT OWNER		TOPO	UTILITIES	STRT / ROAD	LOCATION	CURRENT ASSESSMENT			
HAMMOND DONALD G JR TT			0 Water	0 Feeder	0 Average	Description	Code	Appraised	Assessed
HAMMOND SUSAN C TT			0 No Sewer	0 Paved	0 Average	RESIDNTL	1010	382,900	382,900
102 FRANKLIN ST		SUPPLEMENTAL DATA			RESIDNTL	1010	351,100	351,100	
DUXBURY MA 02332		Alt Prcl ID Scnd Home Tax Class T Tot Fin Area 2232 Total Acres .949 Chapter Lan			Cyclical 3 Exemption W District Res Exem	RESIDNTL	1010	3,600	3,600
GIS ID F_868715_2853547		Assoc Pid#			Total		737,600	737,600	

VISION

RECORD OF OWNERSHIP		BK-VOL/PAGE	SALE DATE	Q/U	V/I	SALE PRICE	VC	PREVIOUS ASSESSMENTS (HISTORY)					
HAMMOND DONALD G JR TT		55682 248	09-20-2021	U	I	1	1A	Year	Code	Assessed	Year	Code	Assessed
HAMMOND SUSAN C		34711 0255	06-22-2007	U	I	100	1A	2023	1010	380,400	2022	1010	341,100
									1010	366,200		1010	301,800
									1010	2,400		1010	2,400
								Total		749,000	Total		645,300
								Total			Total		597,300

EXEMPTIONS			OTHER ASSESSMENTS					
Year	Code	Description	Amount	Code	Description	Number	Amount	Comm Int
Total			0.00					

This signature acknowledges a visit by a Data Collector or Assessor

ASSESSING NEIGHBORHOOD			
Nbhd	Nbhd Name	B	Tracing
0050			Batch

APPRAISED VALUE SUMMARY	
Appraised Bldg. Value (Card)	382,900
Appraised Xf (B) Value (Bldg)	0
Appraised Ob (B) Value (Bldg)	3,600
Appraised Land Value (Bldg)	351,100
Special Land Value	0
Total Appraised Parcel Value	737,600
Valuation Method	C
Total Appraised Parcel Value	737,600

BUILDING PERMIT RECORD							VISIT / CHANGE HISTORY							
Permit Id	Issue Date	Type	Description	Amount	Insp Date	% Comp	Date Comp	Comments	Date	Id	Type	Is	Cd	Purpose/Result
5	01-09-2012	RM	Remodel	6,200	08-01-2012	100		FIN BASEMENT	10-14-2021	SJT	10		00	Measure & Listed
174	10-12-2011	MN	Maintenance	3,800		100		3 REPL WINDOWS	04-12-2013	VGS			20	Field Review
134	08-16-2011	MN	Maintenance	33,700		100		26 ANDERSON WINDOWS	10-11-2012	KP	6		30	Quality Control
									05-30-2007	BSB		1	00	Measure & Listed

LAND LINE VALUATION SECTION															
B	Use Code	Description	Zone	Land Type	Land Units	Unit Price	Size Adj	Site Index	Cond.	Nbhd.	Nbhd. Adj	Notes	Location Adjustment	Adj Unit P	Land Value
1	1010	Single Family	RC	Primary	40,000 SF	8.75	1.00000	5	1.00	0050	1.000		1.0000	8.75	350,000
1	1010	Single Family	RC	Residual	0.032 AC	35,000.00	1.00000	5	1.00	0050	1.000		1.0000	0.80	1,100
Total Card Land Units					0.95 AC	Parcel Total Land Area					0.95	Total Land Value			351,100

CONSTRUCTION DETAIL			CONSTRUCTION DETAIL (CONTINUED)		
Element	Cd	Description	Element	Cd	Description
Style	11	Antique	Bsmt Area	794	
Model	01	Residential	Bsmt Type	04	
Grade	05	Ave/Good	Unfin Area	247.00	Full
Stories	2				
Occupancy	1				
Exterior Wall 1	14	Wood Shingle			
Exterior Wall 2					
Roof Structure	03	Gable			
Roof Cover	03	Asphalt			
Interior Wall 1	05	Drywall			
Interior Wall 2					
Interior Floor 1	09	Pine/Soft Wood			
Interior Floor 2					
Heat Fuel	02	Oil			
Heat Type	04	Forced Air-Duc			
AC Type	06	Partial			
Bedrooms	3				
Full Baths	2				
Half Baths	0				
Extra Fixtures	1				
Total Rooms	8				
Bath Style	02	Average			
Kitchen Style	02	Average			
Extra Kitchens	0				
Fireplaces	4				
Extra Openings	0				
Gas Fireplaces	0				
Sq Ft Fin Bsmt	425				
FBM Quality	05	Living Area			
Foundation	03	Stone			
Bsmt Garage	0				
Bsmt Area	794				

CONDO DATA			
Parcel Id		C	Own
		B	S
Adjust Type	Code	Description	Factor%
Condo Flr			
Condo Unit			

COST / MARKET VALUATION	
Net Other Adj	460,428
Replace Cost	43,453
Year Built	503,881
Effective Year Built	1710
Depreciation Code	1997
Remodel Rating	VG
Year Remodeled	
Depreciation %	24
Functional Obsol	
External Obsol	
Trend Factor	1.000
Condition	
Condition %	
Percent Good	76
Cns Sect Rcnd	382,900
Dep % Ovr	
Dep Ovr Comment	
Misc Imp Ovr	
Misc Imp Ovr Comment	
Cost to Cure Ovr	
Cost to Cure Ovr Comment	

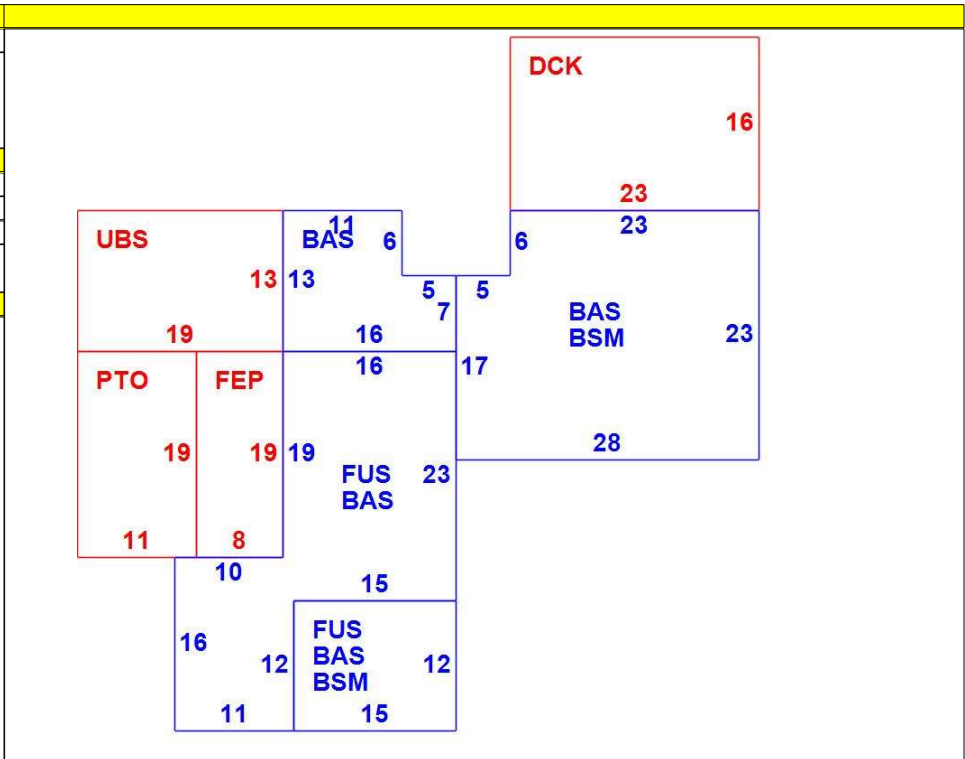

OB - OUTBUILDING & YARD ITEMS(L) / XF - BUILDING EXTRA FEATURES(B)

Code	Description	L/B	Units	Unit Price	Yr Blt	Cond. Cd	% Gd	Grade	Grade Adj.	Appr. Value
SHD1	Shed	L	247	21.00	1965	A	70	C	1.00	3,600

BUILDING SUB-AREA SUMMARY SECTION

Code	Description	Living Area	Floor Area	Eff Area	Unit Cost	Undeprec Value
BAS	First Floor	1,512	1,512	1,512	173.55	262,408
BSM	Basement	0	794	159	34.75	27,594
DCK	Deck	0	368	37	17.45	6,421
FEP	Finished Enclosed Porch	0	152	91	103.90	15,793
FUS	Finished Upper Story	720	720	720	173.55	124,956
PTO	Patio	0	209	10	8.30	1,736
UBS	Unfinished First Fl	0	247	124	87.13	21,520
Ttl Gross Liv / Lease Area		2,232	4,002	2,653		460,428

