

| CURRENT OWNER | | TOPO | UTILITIES | STRT / ROAD | LOCATION | CURRENT ASSESSMENT | | | |
|-------------------------|--|---|------------|--------------|---|--------------------|-----------|-----------|----------|
| PRUDENTE JOHN M | | | 0 Water | 0 Cul-De-Sac | 0 Average | Description | Code | Appraised | Assessed |
| PRUDENTE ELIZABETH | | | 0 No Sewer | 0 Paved | 0 Average | RESIDNTL | 1010 | 807,200 | 807,200 |
| 25 UNION HALL RD | | SUPPLEMENTAL DATA | | | 0 Light | RES LAND | 1010 | 491,700 | 491,700 |
| DUXBURY MA 02332 | | Alt Prcl ID Scnd Home Tax Class T Tot Fin Area 3472 Total Acres 1.03 Chapter Lan | | | Cyclical 3 Exemption W District Res Exem | RESIDNTL | 1010 | 44,000 | 44,000 |
| GIS ID F_868041_2853253 | | Assoc Pid# | | | Total | | 1,342,900 | 1,342,900 | |

905
 DUXBURY, MA
VISION

| RECORD OF OWNERSHIP | | BK-VOL/PAGE | SALE DATE | Q/U | V/I | SALE PRICE | VC | PREVIOUS ASSESSMENTS (HISTORY) | | | | | | | | |
|-----------------------|--|-------------|------------|-----|-----|------------|----|--------------------------------|------|----------|------|-----------|----------|-------|------|----------|
| PRUDENTE JOHN M | | 36238 0252 | 08-01-2008 | Q | I | 931,000 | 00 | Year | Code | Assessed | Year | Code | Assessed | Year | Code | Assessed |
| SCHAEFFER DIANA LYNNE | | 30313 0102 | 04-08-2005 | U | I | 1 | 1A | 2023 | 1010 | 615,600 | 2022 | 1010 | 563,800 | 2021 | 1010 | 479,900 |
| | | | | | | | | | 1010 | 480,200 | | 1010 | 405,200 | | 1010 | 366,500 |
| | | | | | | | | | 1010 | 31,400 | | 1010 | 31,400 | | 1010 | 31,400 |
| | | Total | | | | | | 1,127,200 | | Total | | 1,000,400 | | Total | | 877,800 |

| EXEMPTIONS | | | | OTHER ASSESSMENTS | | | | This signature acknowledges a visit by a Data Collector or Assessor | | | | |
|------------|------|-------------|--------|-------------------|-------------|--------|--------|---|--|--|--|--|
| Year | Code | Description | Amount | Code | Description | Number | Amount | Comm Int | | | | |
| Total | | | 0.00 | | | | | | | | | |

| ASSESSING NEIGHBORHOOD | | | | | | APPRAISED VALUE SUMMARY | | | |
|------------------------|-----------|---|---------|-------|--|--|--|--|--|
| Nbhd | Nbhd Name | B | Tracing | Batch | | | | | |
| 0070 | | | | | | | | | |
| NOTES | | | | | | APPRAISED VALUE SUMMARY | | | |
| | | | | | | Appraised Bldg. Value (Card) 807,200 | | | |
| | | | | | | Appraised Xf (B) Value (Bldg) 0 | | | |
| | | | | | | Appraised Ob (B) Value (Bldg) 44,000 | | | |
| | | | | | | Appraised Land Value (Bldg) 491,700 | | | |
| | | | | | | Special Land Value 0 | | | |
| | | | | | | Total Appraised Parcel Value 1,342,900 | | | |
| | | | | | | Valuation Method C | | | |
| | | | | | | Total Appraised Parcel Value 1,342,900 | | | |

| BUILDING PERMIT RECORD | | | | | | | | VISIT / CHANGE HISTORY | | | | | | | |
|------------------------|------------|------|---------------|--------|------------|--------|-----------|------------------------|------------|-----|------|----|----|------------------|--|
| Permit Id | Issue Date | Type | Description | Amount | Insp Date | % Comp | Date Comp | Comments | Date | Id | Type | Is | Cd | Purpose/Result | |
| 164 | 09-08-2011 | RM | Remodel | 15,000 | | 100 | | KITCHEN & EX WALL | 04-12-2013 | VGS | | | 20 | Field Review | |
| 120000079 | 02-24-2000 | RM | Remodel | 70,000 | 03-19-2001 | 100 | | ADDS DECK PLAN X-179 | 03-28-2013 | AO | 6 | 6 | 30 | Quality Control | |
| 14326 | 12-13-1996 | NC | New Construct | 5,000 | 08-06-1997 | 100 | | 21X16 DECK | 03-19-2001 | KP | | 1 | 00 | Measure & Listed | |
| 13666 | 05-23-1995 | NC | New Construct | 2,000 | 05-23-1996 | 100 | | 10X16 POOL HOUSE | | | | | | | |
| 12311 | 05-12-1992 | NC | New Construct | 400 | 01-01-1993 | 100 | | STORAGE SHED 8X8 | | | | | | | |
| 12248 | 03-18-1992 | NC | New Construct | 16,000 | 01-01-1993 | 100 | | 24X44 INGR POOL | | | | | | | |
| 12201 | 01-22-1992 | AD | Addition | 11,000 | 01-01-1993 | 100 | | REPLACE DK W/NEW BIG | | | | | | | |

| LAND LINE VALUATION SECTION | | | | | | | | | | | | | | | |
|-----------------------------|----------|---------------|------|-----------|------------|--------------|------------------------|------------|-------|-------|-----------|-------|---------------------|------------|------------|
| B | Use Code | Description | Zone | Land Type | Land Units | Unit Price | Size Adj | Site Index | Cond. | Nbhd. | Nbhd. Adj | Notes | Location Adjustment | Adj Unit P | Land Value |
| 1 | 1010 | Single Family | PD | Primary | 40,000 | SF 8.75 | 1.00000 | 5 | 1.00 | 0070 | 1.389 | | 1.0000 | 12.16 | 486,200 |
| 1 | 1010 | Single Family | RC | Residual | 0.112 | AC 35,000.00 | 1.00000 | 5 | 1.00 | 0070 | 1.389 | | 1.0000 | 1.12 | 5,500 |
| Total Card Land Units | | | | | 1.03 | AC | Parcel Total Land Area | | | | | 1.03 | Total Land Value | | 491,700 |

| CONSTRUCTION DETAIL | | | CONSTRUCTION DETAIL (CONTINUED) | | |
|---------------------|------|-------------|---------------------------------|------|-------------|
| Element | Cd | Description | Element | Cd | Description |
| Style | 03 | Colonial | Bsmt Area | 1492 | |
| Model | 01 | Residential | Bsmt Type | 04 | |
| Grade | 07 | Very Good | Unfin Area | 0.00 | Full |
| Stories | 2 | | | | |
| Occupancy | 1 | | | | |
| Exterior Wall 1 | 11 | Clapboard | | | |
| Exterior Wall 2 | | | | | |
| Roof Structure | 03 | Gable | | | |
| Roof Cover | 03 | Asphalt | | | |
| Interior Wall 1 | 05 | Drywall | | | |
| Interior Wall 2 | | | | | |
| Interior Floor 1 | 12 | Hardwood | | | |
| Interior Floor 2 | | | | | |
| Heat Fuel | 02 | Oil | | | |
| Heat Type | 05 | Hot Water | | | |
| AC Type | 01 | None | | | |
| Bedrooms | 4 | | | | |
| Full Baths | 3 | | | | |
| Half Baths | 0 | | | | |
| Extra Fixtures | 3 | | | | |
| Total Rooms | 9 | | | | |
| Bath Style | 03 | Modern | | | |
| Kitchen Style | 03 | Modern | | | |
| Extra Kitchens | 0 | | | | |
| Fireplaces | 2 | | | | |
| Extra Openings | 0 | | | | |
| Gas Fireplaces | 0 | | | | |
| Sq Ft Fin Bsmt | 460 | | | | |
| FBM Quality | 03 | Average | | | |
| Foundation | 06 | Poured Conc | | | |
| Bsmt Garage | 0 | | | | |
| Bsmt Area | 1492 | | | | |

| CONDO DATA | | | |
|-------------|------|-------------|---------|
| Parcel Id | C | B | S |
| Adjust Type | Code | Description | Factor% |
| Condo Flr | | | |
| Condo Unit | | | |

| COST / MARKET VALUATION | |
|--------------------------|---------|
| Net Other Adj | 875,233 |
| Replace Cost | 52,640 |
| Year Built | 1982 |
| Effective Year Built | 2008 |
| Depreciation Code | E |
| Remodel Rating | |
| Year Remodeled | |
| Depreciation % | 13 |
| Functional Obsol | |
| External Obsol | |
| Trend Factor | 1.000 |
| Condition | |
| Condition % | |
| Percent Good | 87 |
| Cns Sect Rcnld | 807,200 |
| Dep % Ovr | |
| Dep Ovr Comment | |
| Misc Imp Ovr | |
| Misc Imp Ovr Comment | |
| Cost to Cure Ovr | |
| Cost to Cure Ovr Comment | |

| OB - OUTBUILDING & YARD ITEMS(L) / XF - BUILDING EXTRA FEATURES(B) | | | | | | | | | | |
|--|---------------|-----|-------|------------|--------|----------|------|-------|------------|-------------|
| Code | Description | L/B | Units | Unit Price | Yr Blt | Cond. Cd | % Gd | Grade | Grade Adj. | Appr. Value |
| SPL2 | Ing Pool-Good | L | 450 | 89.00 | 1992 | A | 70 | C | 1.00 | 28,000 |
| PAV2 | Paving - Conc | L | 500 | 9.00 | 1992 | A | 70 | C | 1.00 | 3,200 |
| BTH | Cabana | L | 160 | 106.00 | 1995 | A | 70 | C | 1.00 | 11,900 |
| SHD1 | Shed | L | 64 | 21.00 | 1992 | A | 70 | C | 1.00 | 900 |

| BUILDING SUB-AREA SUMMARY SECTION | | | | | | |
|-----------------------------------|----------------------|-------------|------------|----------|-----------|----------------|
| Code | Description | Living Area | Floor Area | Eff Area | Unit Cost | Undeprec Value |
| BAS | First Floor | 1,492 | 1,492 | 1,492 | 204.11 | 304,535 |
| BSM | Basement | 0 | 1,492 | 298 | 40.77 | 60,825 |
| DCK | Deck | 0 | 1,048 | 105 | 20.45 | 21,432 |
| FGR | Garage | 0 | 840 | 336 | 81.64 | 68,582 |
| FOP | Open Porch | 0 | 513 | 77 | 30.64 | 15,717 |
| FUS | Finished Upper Story | 1,980 | 1,980 | 1,980 | 204.11 | 404,142 |
| Ttl Gross Liv / Lease Area | | 3,472 | 7,365 | 4,288 | | 875,233 |

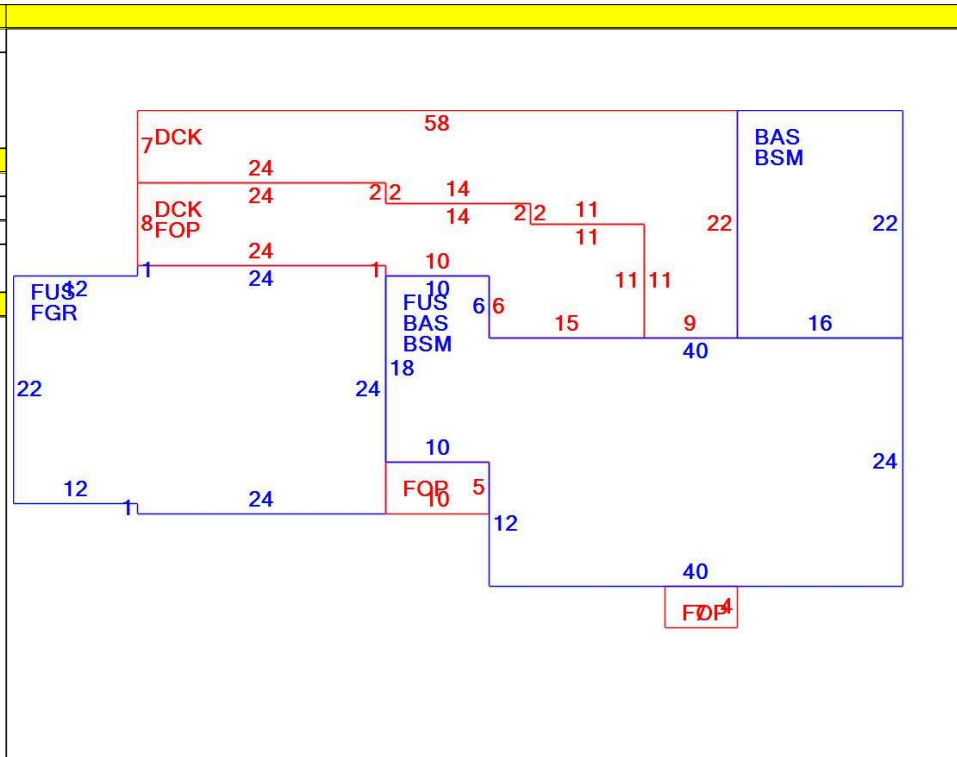

25 UNION HALL RD

