

| CURRENT OWNER | | TOPO | UTILITIES | STRT / ROAD | LOCATION | CURRENT ASSESSMENT | | | |
|--------------------------|-------------------------|------------|------------|-------------|-----------|--------------------|------|-----------|-----------|
| PHILBRICK DAVID E | | | 0 Water | 0 Arterial | 0 Average | Description | Code | Appraised | Assessed |
| PHILBRICK ELAINE M | | | 0 No Sewer | 0 Paved | 0 Average | RESIDNTL | 1010 | 896,400 | 896,400 |
| 307 CONGRESS ST | | | | 0 Heavy | | RES LAND | 1010 | 413,300 | 413,300 |
| SUPPLEMENTAL DATA | | | | | | RESIDNTL | 1010 | 152,900 | 152,900 |
| DUXBURY MA 02332 | Alt Prcl ID | Cyclical 4 | | | | | | | |
| | Scnd Home | Exemption | | | | | | | |
| | Tax Class T | W | | | | | | | |
| | Tot Fin Area 4160 | District | | | | | | | |
| | Total Acres 1.344 | Res Exem | | | | | | | |
| | Chapter Lan | | | | | | | | |
| | GIS ID F_864698_2846045 | Assoc Pid# | | | | | | | |
| | | | | | | Total | | 1,462,600 | 1,462,600 |

905
 DUXBURY, MA
VISION

| RECORD OF OWNERSHIP | | BK-VOL/PAGE | SALE DATE | Q/U | V/I | SALE PRICE | VC | PREVIOUS ASSESSMENTS (HISTORY) | | | | | | | | |
|---------------------------|-------|-------------|------------|-----|-----|------------|----|--------------------------------|------|-----------|-------|------|-----------|-------|------|----------|
| PHILBRICK DAVID E | 12541 | 0342 | 12-29-1993 | U | I | 238,680 | 1A | Year | Code | Assessed | Year | Code | Assessed | Year | Code | Assessed |
| MCLEAN MARJORIE E TRUSTEE | 12269 | 0329 | 10-06-1993 | U | I | 100 | 1A | 2023 | 1010 | 676,200 | 2022 | 1010 | 617,700 | 2021 | 1010 | 511,300 |
| | | | | | | | | | 1010 | 429,800 | | 1010 | 384,300 | | 1010 | 320,200 |
| | | | | | | | | | 1010 | 113,800 | | 1010 | 113,800 | | 1010 | 113,800 |
| | | | | | | | | Total | | 1,219,800 | Total | | 1,115,800 | Total | | 945,300 |

| EXEMPTIONS | | | OTHER ASSESSMENTS | | | | | This signature acknowledges a visit by a Data Collector or Assessor | | | | | | | | | | |
|------------|------|-------------|-------------------|------|-------------|--------|--------|---|--|--|--|--|--|--|--|--|--|--|
| Year | Code | Description | Amount | Code | Description | Number | Amount | Comm Int | | | | | | | | | | |
| | | | | | | | | | | | | | | | | | | |
| Total | | | 0.00 | | | | | | | | | | | | | | | |

| ASSESSING NEIGHBORHOOD | | | | | | APPRAISED VALUE SUMMARY | | | | | | | | | | |
|------------------------|-----------|---|---------|-------|-------------------------------|-------------------------|--|--|--|--|-----------|--|--|--|--|--|
| Nbhd | Nbhd Name | B | Tracing | Batch | | | | | | | | | | | | |
| 0050 | | | | | Appraised Bldg. Value (Card) | | | | | | 896,400 | | | | | |
| | | | | | Appraised Xf (B) Value (Bldg) | | | | | | 0 | | | | | |
| | | | | | Appraised Ob (B) Value (Bldg) | | | | | | 152,900 | | | | | |
| | | | | | Appraised Land Value (Bldg) | | | | | | 413,300 | | | | | |
| | | | | | Special Land Value | | | | | | 0 | | | | | |
| | | | | | Total Appraised Parcel Value | | | | | | 1,462,600 | | | | | |
| | | | | | Valuation Method | | | | | | C | | | | | |
| | | | | | Total Appraised Parcel Value | | | | | | 1,462,600 | | | | | |

| BUILDING PERMIT RECORD | | | | | | | | | | VISIT / CHANGE HISTORY | | | | | |
|------------------------|------------|------|---------------|--------|------------|--------|-----------|----------------------|--|------------------------|-----|------|----|----|------------------|
| Permit Id | Issue Date | Type | Description | Amount | Insp Date | % Comp | Date Comp | Comments | | Date | Id | Type | Is | Cd | Purpose/Result |
| 80 | 04-14-2010 | AD | Addition | 83,500 | 08-03-2011 | 100 | | 132'G,484'OVGAR,FP,V | | 11-08-2022 | SJT | 10 | | 00 | Measure & Listed |
| 67 | 05-19-2009 | NC | New Construct | 12,000 | 08-03-2011 | 100 | | 12X16 UTIL BLDG | | 04-12-2013 | VGS | | | 20 | Field Review |
| 214 | 06-14-2006 | MS | Miscellaneous | 47,000 | 09-11-2007 | 100 | | 14X42 POOL CABANA | | 07-07-2011 | KP | | 1 | 00 | Measure & Listed |
| 333 | 07-15-2005 | MS | Miscellaneous | 50,000 | 06-30-2006 | 100 | | 16X35 INGR HEAT POOL | | | | | | | |
| 20010103 | 04-02-2001 | AD | Addition | 90,000 | 08-05-2003 | 100 | | 2-ND FL, DECK, PORCH | | | | | | | |
| 11291 | 06-29-1989 | NC | New Construct | 2,400 | 01-01-1989 | 100 | | UTILITY SHED 8 X 12 | | | | | | | |

| LAND LINE VALUATION SECTION | | | | | | | | | | | | | | | | |
|-----------------------------|----------|---------------|------|-----------|------------|--------------|------------------------|------------|-------|-------|-----------|-------|---------------------|------------|------------|---------|
| B | Use Code | Description | Zone | Land Type | Land Units | Unit Price | Size Adj | Site Index | Cond. | Nbhd. | Nbhd. Adj | Notes | Location Adjustment | Adj Unit P | Land Value | |
| 1 | 1010 | Single Family | RC | Primary | 40,000 | SF 8.75 | 1.00000 | 5 | 1.00 | 0050 | 1.000 | | V115 | 1.1500 | 8.75 | 402,500 |
| 1 | 1010 | Single Family | RC | Residual | 0.302 | AC 35,000.00 | 1.00000 | 5 | 1.00 | 0050 | 1.000 | | | 1.0000 | 0.81 | 10,600 |
| 1 | 1010 | Single Family | RC | Undevelop | 0.125 | AC 2,000.00 | 1.00000 | 0 | 1.00 | 0050 | 1.000 | | | 1.0000 | 0.04 | 200 |
| Total Card Land Units | | | | | 1.34 | AC | Parcel Total Land Area | | | | | 1.34 | Total Land Value | | | 413,300 |

| CONSTRUCTION DETAIL | | | CONSTRUCTION DETAIL (CONTINUED) | | |
|---------------------|------|--------------|---------------------------------|-------|-------------|
| Element | Cd | Description | Element | Cd | Description |
| Style | 03 | Colonial | Bsmt Area | 1348 | |
| Model | 01 | Residential | Bsmt Type | 04 | |
| Grade | 07 | Very Good | Unfin Area | 0.00 | Full |
| Stories | 2 | | | | |
| Occupancy | 1 | | CONDO DATA | | |
| Exterior Wall 1 | 14 | Wood Shingle | Parcel Id | | C |
| Exterior Wall 2 | | | | | B |
| Roof Structure | 03 | Gable | Adjust Type | Code | Description |
| Roof Cover | 03 | Asphalt | Condo Flr | | |
| Interior Wall 1 | 05 | Drywall | Condo Unit | | |
| Interior Wall 2 | | | COST / MARKET VALUATION | | |
| Interior Floor 1 | 12 | Hardwood | Net Other Adj | | 986,179 |
| Interior Floor 2 | | | Replace Cost | | 56,160 |
| Heat Fuel | 02 | Oil | Year Built | | 1,042,338 |
| Heat Type | 05 | Hot Water | Effective Year Built | | 1968 |
| AC Type | 03 | Central | Depreciation Code | | 2007 |
| Bedrooms | 4 | | Remodel Rating | | E |
| Full Baths | 3 | | Year Remodeled | | |
| Half Baths | 1 | | Depreciation % | 14 | |
| Extra Fixtures | 3 | | Functional Obsol | | |
| Total Rooms | 10 | | External Obsol | | |
| Bath Style | 03 | Modern | Trend Factor | 1.000 | |
| Kitchen Style | 03 | Modern | Condition | | |
| Extra Kitchens | 0 | | Condition % | | |
| Fireplaces | 2 | | Percent Good | 86 | |
| Extra Openings | 0 | | Cns Sect Rcnd | | 896,400 |
| Gas Fireplaces | 0 | | Dep % Ovr | | |
| Sq Ft Fin Bsmt | 448 | | Dep Ovr Comment | | |
| FBM Quality | 03 | Average | Misc Imp Ovr | | |
| Foundation | 06 | Poured Conc | Misc Imp Ovr Comment | | |
| Bsmt Garage | 0 | | Cost to Cure Ovr | | |
| Bsmt Area | 1348 | | Cost to Cure Ovr Comment | | |

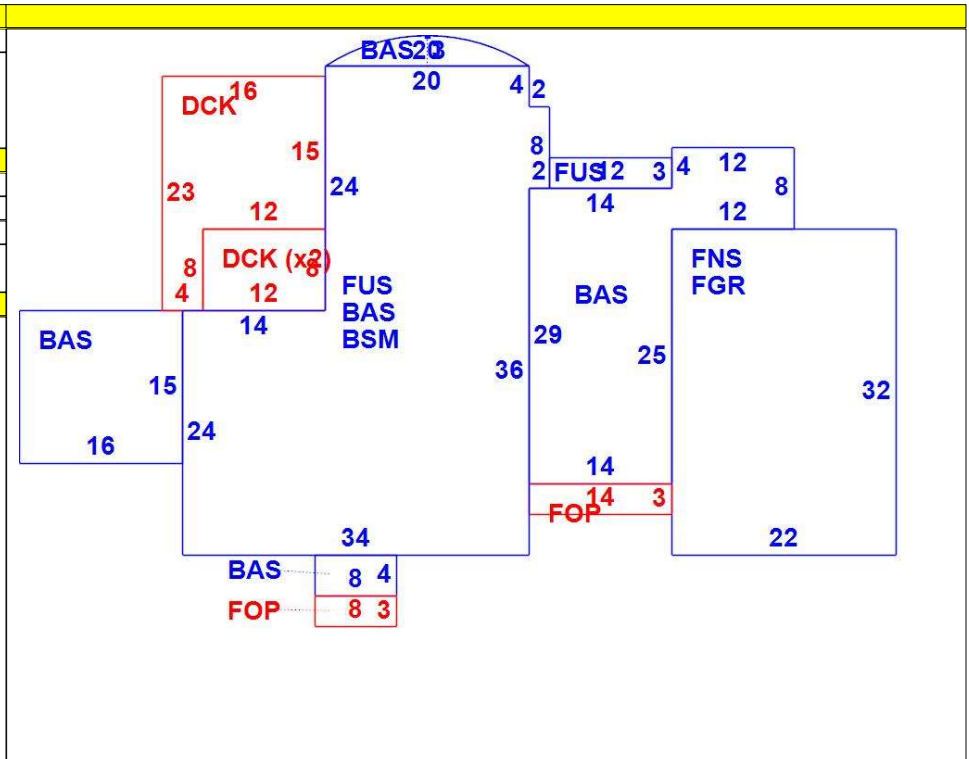

| OB - OUTBUILDING & YARD ITEMS(L) / XF - BUILDING EXTRA FEATURES(B) | | | | | | | | | | |
|--|----------------|-----|-------|------------|--------|----------|------|-------|------------|-------------|
| Code | Description | L/B | Units | Unit Price | Yr Blt | Cond. Cd | % Gd | Grade | Grade Adj. | Appr. Value |
| SPL1 | Ing Pool - Ave | L | 560 | 64.00 | 2005 | G | 85 | B | 1.50 | 45,700 |
| HTB | Hot Tub | L | 1 | 10500.00 | 2005 | G | 85 | B | 1.50 | 13,400 |
| PHS | Pool House | L | 570 | 143.00 | 2006 | G | 85 | C | 1.00 | 69,300 |
| PTO | Patio | L | 550 | 15.00 | 2006 | G | 85 | C | 1.00 | 7,000 |
| PERG | PERGOLA | L | 182 | 35.00 | 2006 | G | 85 | C | 1.00 | 5,400 |
| SHD1 | Shed | L | 192 | 21.00 | 2011 | G | 85 | C | 1.00 | 3,400 |
| GNR | GENERATOR | L | 1 | 12400.00 | 2018 | A | 70 | C | 1.00 | 8,700 |

| BUILDING SUB-AREA SUMMARY SECTION | | | | | | |
|-----------------------------------|----------------------|-------------|------------|----------|-----------|----------------|
| Code | Description | Living Area | Floor Area | Eff Area | Unit Cost | Undeprec Value |
| BAS | First Floor | 2,127 | 2,127 | 2,127 | 209.42 | 445,445 |
| BSM | Basement | 0 | 1,312 | 262 | 41.82 | 54,869 |
| DCK | Deck | 0 | 464 | 46 | 20.76 | 9,634 |
| FGR | Garage | 0 | 704 | 282 | 83.89 | 59,058 |
| FNS | Finished 90% Story | 634 | 704 | 634 | 188.60 | 132,775 |
| FOP | Open Porch | 0 | 66 | 10 | 31.73 | 2,094 |
| FUS | Finished Upper Story | 1,348 | 1,348 | 1,348 | 209.42 | 282,304 |
| Ttl Gross Liv / Lease Area | | 4,109 | 6,725 | 4,709 | | 986,179 |

