

| CURRENT OWNER | | TOPO | | UTILITIES | | STRT / ROAD | | LOCATION | | CURRENT ASSESSMENT | | | | 905 DUXBURY, MA | | | | |
|---|------------|---|-------------|---|------------|------------------------|-------------|---|------------|--------------------|-----------|--------------------------------|--|---------------------|-------------------------------|---------------|------------------|---------|
| COFFEY ALFRED G JR COFFEY JOSEPHINE M 580 CHANDLER ST DUXBURY MA 02332 | | 0 | Water | 0 | Arterial | 0 | Average | Description | Code | Appraised | Assessed | | 282,800 282,800 368,600 368,600 | | | | | |
| | | 0 | No Sewer | 0 | Paved | 0 | Average | RESIDENTL | 1010 | 282,800 | | | | | | | | |
| | | | | 0 | Heavy | | | RES LAND | 1010 | 368,600 | | | VISION | | | | | |
| | | SUPPLEMENTAL DATA | | | | | | | | | | | | | | | | |
| | | Alt Prcl ID Scnd Home Tax Class T Tot Fin Area 1547 Total Acres 1.448 Chapter Lan GIS ID F_866210_2844746 | | Cyclical 4 Exemption W District Res Exem Assoc Pid# | | | | | | | | | | | | | | |
| | | | | | | | | Total | | 651,400 | | 651,400 | | | | | | |
| RECORD OF OWNERSHIP | | | BK-VOL/PAGE | | SALE DATE | | Q/U V/I | | SALE PRICE | | VC | | PREVIOUS ASSESSMENTS (HISTORY) | | | | | |
| COFFEY ALFRED G JR | | | 5770 | 0065 | 08-31-1984 | | U | I | 115,800 | | 1 | Year | Code | Assessed | Year | Code | Assessed | |
| | | | | | | | | | | | | 2023 | 1010 | 223,500 | 2022 | 1010 | 204,400 | |
| | | | | | | | | | | | | | 1010 | 383,300 | | 1010 | 315,900 | |
| | | | | | | | | | | | | Total | | 606,800 | | Total 520,300 | | |
| | | | | | | | | | | | | Total | | 448,100 | | | | |
| EXEMPTIONS | | | | OTHER ASSESSMENTS | | | | This signature acknowledges a visit by a Data Collector or Assessor | | | | | | | | | | |
| Year | Code | Description | | Amount | | Code | Description | Number | Amount | Comm Int | | | | | | | | |
| | | | | | | | | | | | | | | | | | | |
| | | | | Total | | 0.00 | | | | | | | | | | | | |
| ASSESSING NEIGHBORHOOD | | | | | | | | | | | | APPRAISED VALUE SUMMARY | | | | | | |
| Nbhd | | Nbhd Name | | B | | Tracing | | Batch | | | | | | | Appraised Bldg. Value (Card) | | 282,800 | |
| 0050 | | | | | | | | | | | | | | | Appraised Xf (B) Value (Bldg) | | 0 | |
| | | | | | | | | | | | | | | | Appraised Ob (B) Value (Bldg) | | 0 | |
| | | | | | | | | | | | | | | | Appraised Land Value (Bldg) | | 368,600 | |
| | | | | | | | | | | | | | | | Special Land Value | | 0 | |
| | | | | | | | | | | | | | | | Total Appraised Parcel Value | | 651,400 | |
| | | | | | | | | | | | | | | | Valuation Method | | C | |
| | | | | | | | | | | | | | | | Total Appraised Parcel Value | | 651,400 | |
| BUILDING PERMIT RECORD | | | | | | | | | | | | VISIT / CHANGE HISTORY | | | | | | |
| Permit Id | Issue Date | Type | Description | Amount | Insp Date | % Comp | Date Comp | Comments | | | | Date | Id | Type | Is | Cd | Purpose/Result | |
| | | | | | | | | | | | | 10-25-2021 | SJT | 10 | | 00 | Measure & Listed | |
| | | | | | | | | | | | | 03-10-2015 | JLF | 0 | 1 | 00 | Measure & Listed | |
| | | | | | | | | | | | | 04-12-2013 | VGS | | | 20 | Field Review | |
| | | | | | | | | | | | | 05-29-2007 | BSB | | 1 | 00 | Measure & Listed | |
| LAND LINE VALUATION SECTION | | | | | | | | | | | | | | | | | | |
| B | Use Code | Description | Zone | Land Type | Land Units | Unit Price | Size Adj | Site Index | Cond. | Nbhd. | Nbhd. Adj | Notes | | Location Adjustment | | Adj Unit P | Land Value | |
| 1 | 1010 | Single Family | RC | Primary | 40,000 SF | 8.75 | 1.00000 | 5 | 1.00 | 0050 | 1.000 | | | | | 1.0000 | 8.75 | 350,000 |
| 1 | 1010 | Single Family | RC | Residual | 0.530 AC | 35,000.00 | 1.00000 | 5 | 1.00 | 0050 | 1.000 | | | | | 1.0000 | 0.81 | 18,600 |
| Total Card Land Units | | | | | 1.45 AC | Parcel Total Land Area | | | | | 1.45 | Total Land Value | | | | | 368,600 | |

| CONSTRUCTION DETAIL | | | CONSTRUCTION DETAIL (CONTINUED) | | |
|---------------------|-----|--------------|---------------------------------|------|-------------|
| Element | Cd | Description | Element | Cd | Description |
| Style | 03 | Colonial | Bsmt Area | 904 | |
| Model | 01 | Residential | Bsmt Type | 03 | |
| Grade | 05 | Ave/Good | Unfin Area | 0.00 | Partial |
| Stories | 2 | | CONDO DATA | | |
| Occupancy | 1 | | Parcel Id | | C |
| Exterior Wall 1 | 14 | Wood Shingle | | | B |
| Exterior Wall 2 | | | | | S |
| Roof Structure | 03 | Gable | Adjust Type | Code | Description |
| Roof Cover | 03 | Asphalt | Condo Flr | | Factor% |
| Interior Wall 1 | 05 | Drywall | Condo Unit | | |
| Interior Wall 2 | | | COST / MARKET VALUATION | | |
| Interior Floor 1 | 12 | Hardwood | Net Other Adj | | 370,470 |
| Interior Floor 2 | 14 | Carpet | Replace Cost | | 16,900 |
| Heat Fuel | 02 | Oil | Year Built | | 387,370 |
| Heat Type | 05 | Hot Water | Effective Year Built | | 1984 |
| AC Type | 01 | None | Depreciation Code | | 1994 |
| Bedrooms | 3 | | Remodel Rating | | A |
| Full Baths | 2 | | Year Remodeled | | |
| Half Baths | 0 | | Depreciation % | | 27 |
| Extra Fixtures | 0 | | Functional Obsol | | |
| Total Rooms | 6 | | External Obsol | | |
| Bath Style | 02 | Average | Trend Factor | | 1.000 |
| Kitchen Style | 02 | Average | Condition | | |
| Extra Kitchens | 0 | | Condition % | | |
| Fireplaces | 1 | | Percent Good | | 73 |
| Extra Openings | 0 | | Cns Sect Rcnld | | 282,800 |
| Gas Fireplaces | 0 | | Dep % Ovr | | |
| Sq Ft Fin Bsmt | 0 | | Dep Ovr Comment | | |
| FBM Quality | | | Misc Imp Ovr | | |
| Foundation | 06 | Poured Conc | Misc Imp Ovr Comment | | |
| Bsmt Garage | 0 | | Cost to Cure Ovr | | |
| Bsmt Area | 904 | | Cost to Cure Ovr Comment | | |

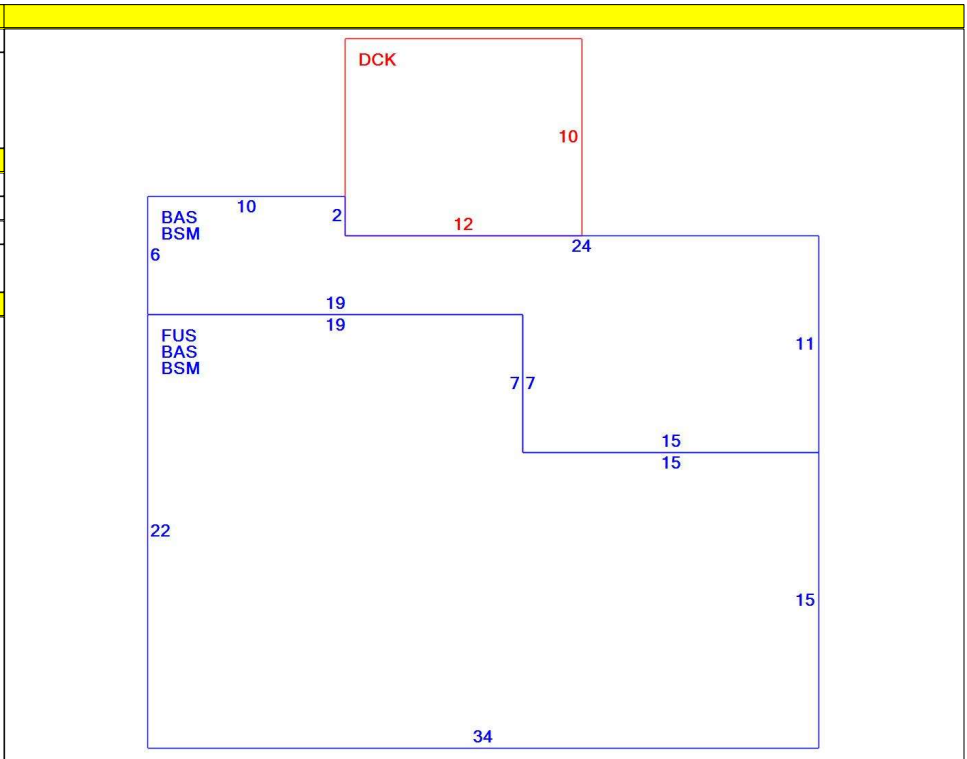

| OB - OUTBUILDING & YARD ITEMS(L) / XF - BUILDING EXTRA FEATURES(B) | | | | | | | | | | |
|--|-------------|-----|-------|------------|--------|----------|------|-------|------------|-------------|
| Code | Description | L/B | Units | Unit Price | Yr Blt | Cond. Cd | % Gd | Grade | Grade Adj. | Appr. Value |
| | | | | | | | | | | |

| BUILDING SUB-AREA SUMMARY SECTION | | | | | | | |
|-----------------------------------|----------------------|-------------|------------|----------|-----------|----------------|--|
| Code | Description | Living Area | Floor Area | Eff Area | Unit Cost | Undeprec Value | |
| BAS | First Floor | 904 | 904 | 904 | 212.91 | 192,474 | |
| BSM | Basement | 0 | 904 | 181 | 42.63 | 38,537 | |
| DCK | Deck | 0 | 120 | 12 | 21.29 | 2,555 | |
| FUS | Finished Upper Story | 643 | 643 | 643 | 212.91 | 136,904 | |
| Ttl Gross Liv / Lease Area | | 1,547 | 2,571 | 1,740 | | 370,470 | |

