

CONSTRUCTION DETAIL			CONSTRUCTION DETAIL (CONTINUED)		
Element	Cd	Description	Element	Cd	Description
Style	03	Colonial	Bsmt Area	1404	
Model	01	Residential	Bsmt Type	04	
Grade	07	Very Good	Unfin Area	0.00	Full
Stories	2				
Occupancy	1		CONDO DATA		
Exterior Wall 1	11	Clapboard	Parcel Id		C
Exterior Wall 2					B
Roof Structure	03	Gable	Adjust Type	Code	Description
Roof Cover	03	Asphalt	Condo Flr		Factor%
Interior Wall 1	05	Drywall	Condo Unit		
Interior Wall 2			COST / MARKET VALUATION		
Interior Floor 1	12	Hardwood	Net Other Adj		737,697
Interior Floor 2			Replace Cost		63,040
Heat Fuel	02	Oil	Year Built		800,737
Heat Type	05	Hot Water	Effective Year Built		1986
AC Type	01	None	Depreciation Code		2003
Bedrooms	4		Remodel Rating		G
Full Baths	2		Year Remodeled		
Half Baths	2		Depreciation %		18
Extra Fixtures	2		Functional Obsol		
Total Rooms	8		External Obsol		
Bath Style	02	Average	Trend Factor		1.000
Kitchen Style	02	Average	Condition		
Extra Kitchens	0		Condition %		
Fireplaces	2		Percent Good		82
Extra Openings	0		Cns Sect Rcnld		656,600
Gas Fireplaces	0		Dep % Ovr		
Sq Ft Fin Bsmt	672		Dep Ovr Comment		
FBM Quality	03	Average	Misc Imp Ovr		
Foundation	06	Poured Conc	Misc Imp Ovr Comment		
Bsmt Garage	0		Cost to Cure Ovr		
Bsmt Area	1404		Cost to Cure Ovr Comment		

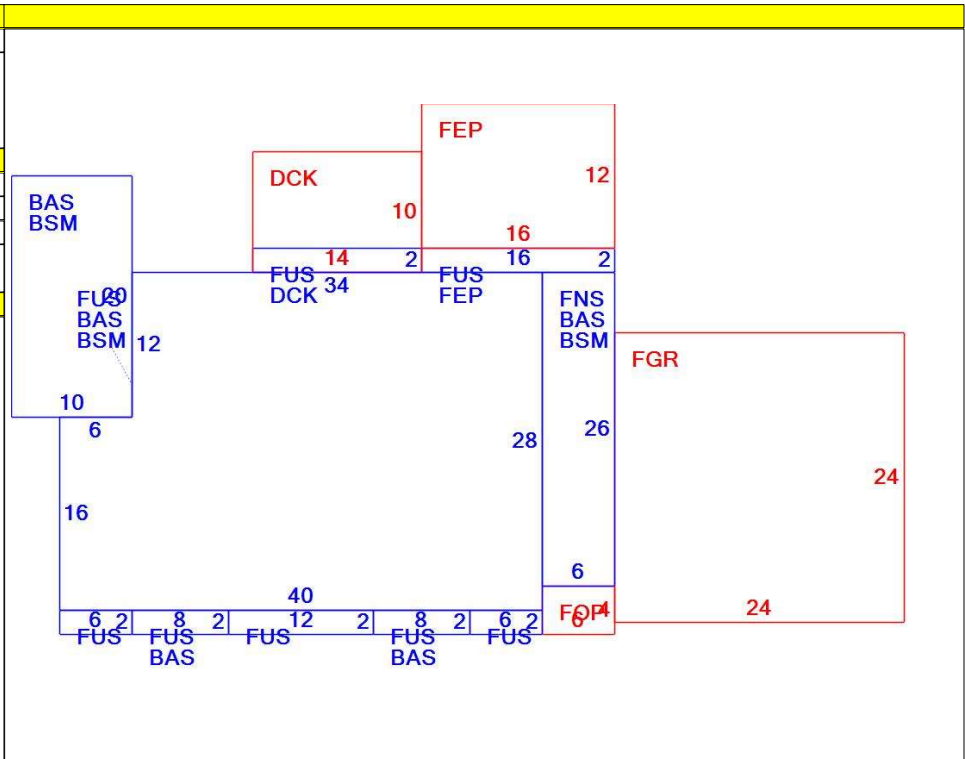

OB - OUTBUILDING & YARD ITEMS(L) / XF - BUILDING EXTRA FEATURES(B)										
Code	Description	L/B	Units	Unit Price	Yr Blt	Cond. Cd	% Gd	Grade	Grade Adj.	Appr. Value
SPL1	Ing Pool - Ave	L	648	64.00	1986	A	70	C	1.00	29,000

BUILDING SUB-AREA SUMMARY SECTION						
Code	Description	Living Area	Floor Area	Eff Area	Unit Cost	Undeprec Value
BAS	First Floor	1,436	1,436	1,436	215.07	308,843
BSM	Basement	0	1,404	281	43.05	60,435
DCK	Deck	0	168	17	21.76	3,656
FEP	Finished Enclosed Porch	0	224	134	128.66	28,820
FGR	Garage	0	576	230	85.88	49,467
FNS	Finished 90% Story	140	156	140	193.01	30,110
FOP	Open Porch	0	24	4	35.85	860
FUS	Finished Upper Story	1,188	1,188	1,188	215.07	255,506
Ttl Gross Liv / Lease Area		2,764	5,176	3,430		737,697



15 MALLARD COVE LN

