

CURRENT OWNER		TOPO	UTILITIES	STRT / ROAD	LOCATION	CURRENT ASSESSMENT				905 DUXBURY, MA VISION					
HANNON THOMAS A			0 Water	0 Subdivision	0 Average	Description	Code	Appraised	Assessed						
HANNON SHEILA W			0 No Sewer	0 Paved	0 Average	RESIDNTL	1010	417,700	417,700						
161 BIANCA RD				0 Medium		RES LAND	1010	350,700	350,700						
SUPPLEMENTAL DATA						RESIDNTL	1010	700	700						
DUXBURY MA 02332		Alt Prcl ID Scnd Home Tax Class T Tot Fin Area 2080 Total Acres .938 Chapter Lan		Cyclical 4 Exemption W District Res Exem											
GIS ID F_863968_2842031		Assoc Pid#						Total	769,100	769,100					
RECORD OF OWNERSHIP		BK-VOL/PAGE	SALE DATE	Q/U	V/I	SALE PRICE	VC	PREVIOUS ASSESSMENTS (HISTORY)							
HANNON THOMAS A		15051 0229	03-26-1997	U	I	180,000	1A	Year	Code	Assessed	Year	Code	Assessed		
HANNON SHEILA W		12915 0336	05-31-1994	Q	I			2023	1010	310,000	2022	1010	257,400		
									1010	504,800		1010	320,700		
									1010	500		1010	500		
								Total		815,300	Total		578,600		
								Total			Total		580,700		
EXEMPTIONS			OTHER ASSESSMENTS					This signature acknowledges a visit by a Data Collector or Assessor							
Year	Code	Description	Amount	Code	Description	Number	Amount	Comm Int							
			0.00												
ASSESSING NEIGHBORHOOD															
Nbhd		Nbhd Name		B		Tracing		Batch							
0050															
NOTES															
BUILDING PERMIT RECORD															
Permit Id	Issue Date	Type	Description	Amount	Insp Date	% Comp	Date Comp	Comments	Date	Id	Type	Is	Cd	Purpose/Result	
19990567	12-15-1999	RM	Remodel	10,000	05-07-2001	100		18X22 RC RM 24X26FGR	09-12-2018	SJD			20	Field Review	
19990565	12-15-1999	DM	Demolish	55,000	05-07-2001	100		DEM AND NC PL X-134	04-12-2013	VGS			20	Field Review	
									09-09-2003	KP		1	00	Measure & Listed	
LAND LINE VALUATION SECTION															
B	Use Code	Description	Zone	Land Type	Land Units	Unit Price	Size Adj	Site Index	Cond.	Nbhd.	Nbhd. Adj	Notes	Location Adjustment	Adj Unit P	Land Value
1	1010	Single Family	RC	Primary	40,000 SF	8.75	1.00000	5	1.00	0050	1.000			1.0000	350,000
1	1010	Single Family	RC	Residual	0.021 AC	35,000.00	1.00000	5	1.00	0050	1.000			1.0000	700
Total Card Land Units					0.94 AC	Parcel Total Land Area					0.94	Total Land Value			350,700

CONSTRUCTION DETAIL			CONSTRUCTION DETAIL (CONTINUED)		
Element	Cd	Description	Element	Cd	Description
Style	04	Cape Cod	Bsmt Area	816	
Model	01	Residential	Bsmt Type	04	
Grade	05	Ave/Good	Unfin Area	312.00	Full
Stories	1.75				
Occupancy	1		CONDO DATA		
Exterior Wall 1	14	Wood Shingle	Parcel Id		C
Exterior Wall 2					B
Roof Structure	03	Gable	Adjust Type	Code	Description
Roof Cover	03	Asphalt	Condo Flr		Factor%
Interior Wall 1	05	Drywall	Condo Unit		
Interior Wall 2			COST / MARKET VALUATION		
Interior Floor 1	12	Hardwood			535,981
Interior Floor 2			Net Other Adj		13,650
Heat Fuel	04	Electric	Replace Cost		549,629
Heat Type	07	Radiant-Elec.	Year Built		1972
AC Type	01	None	Effective Year Built		1997
Bedrooms	3		Depreciation Code		G
Full Baths	1		Remodel Rating		
Half Baths	1		Year Remodeled		
Extra Fixtures	0		Depreciation %		24
Total Rooms	7		Functional Obsol		
Bath Style	02	Average	External Obsol		
Kitchen Style	02	Average	Trend Factor		1.000
Extra Kitchens	0		Condition		
Fireplaces	1		Condition %		
Extra Openings	0		Percent Good		76
Gas Fireplaces	0		Cns Sect Rcnld		417,700
Sq Ft Fin Bsmt	0		Dep % Ovr		
FBM Quality			Dep Ovr Comment		
Foundation	06	Poured Conc	Misc Imp Ovr		
Bsmt Garage	0		Misc Imp Ovr Comment		
Bsmt Area	816		Cost to Cure Ovr		
			Cost to Cure Ovr Comment		

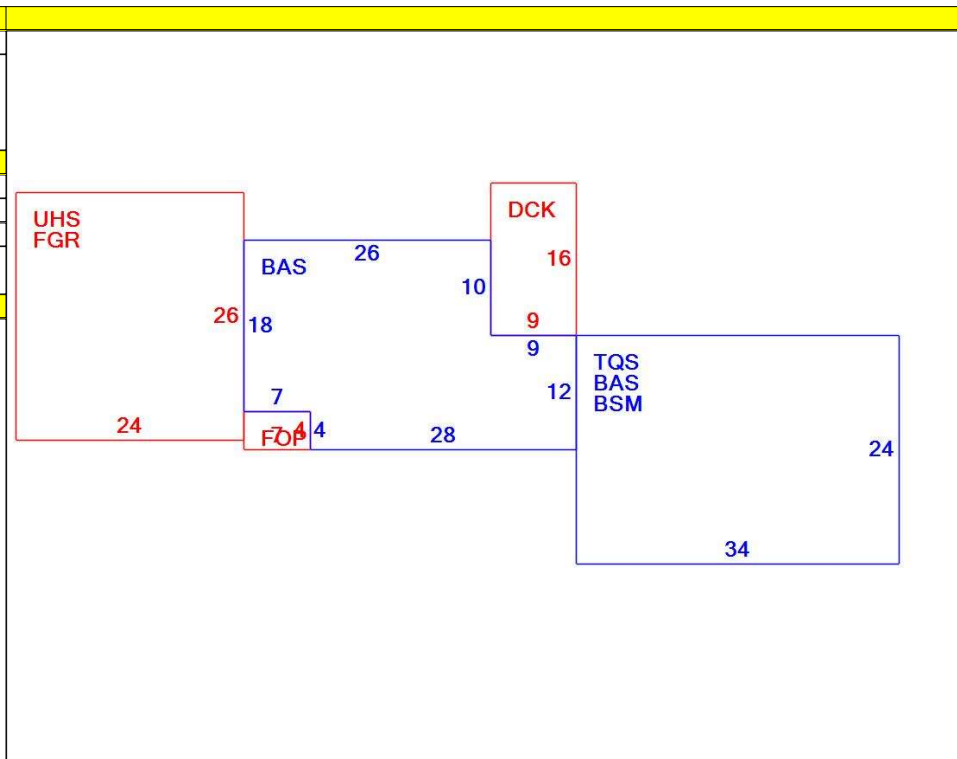

OB - OUTBUILDING & YARD ITEMS(L) / XF - BUILDING EXTRA FEATURES(B)										
Code	Description	L/B	Units	Unit Price	Yr Blt	Cond. Cd	% Gd	Grade	Grade Adj.	Appr. Value
SHD1	Shed	L	50	21.00	1972	A	70	C	1.00	700

BUILDING SUB-AREA SUMMARY SECTION						
Code	Description	Living Area	Floor Area	Eff Area	Unit Cost	Undeprec Value
BAS	First Floor	1,468	1,468	1,468	200.97	295,020
BSM	Basement	0	816	163	40.14	32,758
DCK	Deck	0	144	14	19.54	2,814
FGR	Garage	0	624	250	80.52	50,242
FOP	Open Porch	0	28	4	28.71	804
TQS	Three Quarter Story	612	816	612	150.73	122,992
UHS	Unfinished Half Story	0	624	156	50.24	31,351
Ttl Gross Liv / Lease Area		2,080	4,520	2,667		535,981



161 BIANCA RD

