

| CURRENT OWNER | | TOPO | UTILITIES | STRT / ROAD | LOCATION | CURRENT ASSESSMENT | | | | |
|------------------------------|--|--------------------------|------------|--------------|-----------|--------------------|-------|-----------|----------|------------------------|
| SHANNON MARCIA A TT | | | 0 Water | 0 Cul-De-Sac | 0 Average | Description | Code | Appraised | Assessed | 905 DUXBURY, MA |
| MARCIA A SHANNON REVOCABLE T | | | 0 No Sewer | 0 Paved | 0 Average | RESIDNTL | 1010 | 303,900 | 303,900 | |
| 15 TURKEY RIDGE LN | | | | 0 Light | | RES LAND | 1010 | 355,500 | 355,500 | |
| DUXBURY MA 02332 | | SUPPLEMENTAL DATA | | | RESIDNTL | 1010 | 1,500 | 1,500 | | |
| Alt Prcl ID | | Cyclical 4 | | | | | | | | |
| Scnd Home | | Exemption | | | | | | | | |
| Tax Class T | | W | | | | | | | | |
| Tot Fin Area 1820 | | District | | | | | | | | |
| Total Acres 1.07 | | Res Exem | | | | | | | | |
| Chapter Lan | | | | | | | | | | |
| GIS ID F_863917_2839954 | | Assoc Pid# | | | | | | | | |
| | | | | | | | Total | 660,900 | 660,900 | |

VISION

| RECORD OF OWNERSHIP | | BK-VOL/PAGE | SALE DATE | Q/U | V/I | SALE PRICE | VC | PREVIOUS ASSESSMENTS (HISTORY) | | | | | | | | |
|---------------------|--|-------------|------------|-----|-----|------------|-------|--------------------------------|-------|----------|-------|---------|----------|------|------|----------|
| SHANNON MARCIA A TT | | 47556 0340 | 10-04-2016 | U | I | 1 | 1A | Year | Code | Assessed | Year | Code | Assessed | Year | Code | Assessed |
| SHANNON PETER F | | 6039 0120 | 04-04-1985 | Q | I | 125,000 | 00 | 2023 | 1010 | 241,200 | 2022 | 1010 | 225,000 | 2021 | 1010 | 217,600 |
| | | | | | | | | | 1010 | 511,400 | | 1010 | 324,900 | | 1010 | 313,400 |
| | | | | | | | | | 1010 | 1,000 | | 1010 | 1,000 | | 1010 | 1,000 |
| | | | | | | | Total | 753,600 | Total | 550,900 | Total | 532,000 | | | | |

| EXEMPTIONS | | | OTHER ASSESSMENTS | | | | | |
|------------|------|-------------|-------------------|------|-------------|--------|--------|----------|
| Year | Code | Description | Amount | Code | Description | Number | Amount | Comm Int |
| | | | | | | | | |
| Total | | | 0.00 | | | | | |

This signature acknowledges a visit by a Data Collector or Assessor

| ASSESSING NEIGHBORHOOD | | | | |
|------------------------|-----------|---|---------|-------|
| Nbhd | Nbhd Name | B | Tracing | Batch |
| 0050 | | | | |

| APPRAISED VALUE SUMMARY | |
|-------------------------------|---------|
| Appraised Bldg. Value (Card) | 303,900 |
| Appraised Xf (B) Value (Bldg) | 0 |
| Appraised Ob (B) Value (Bldg) | 1,500 |
| Appraised Land Value (Bldg) | 355,500 |
| Special Land Value | 0 |
| Total Appraised Parcel Value | 660,900 |
| Valuation Method | C |
| Total Appraised Parcel Value | 660,900 |

| BUILDING PERMIT RECORD | | | | | | | | | | VISIT / CHANGE HISTORY | | | | | |
|------------------------|------------|------|-------------|--------|-----------|--------|-----------|----------|--|------------------------|-----|------|----|----|------------------|
| Permit Id | Issue Date | Type | Description | Amount | Insp Date | % Comp | Date Comp | Comments | | Date | Id | Type | Is | Cd | Purpose/Result |
| | | | | | | | | | | 09-12-2018 | SJD | | | 20 | Field Review |
| | | | | | | | | | | 04-12-2013 | VGS | | | 20 | Field Review |
| | | | | | | | | | | 07-26-2007 | BSB | | 1 | 00 | Measure & Listed |

| LAND LINE VALUATION SECTION | | | | | | | | | | | | | | | | | | |
|-----------------------------|----------|---------------|------|-----------|------------|------------------------|----------|------------|-------|-------|-----------|------------------|--|---------------------|--|------------|------------|---------|
| B | Use Code | Description | Zone | Land Type | Land Units | Unit Price | Size Adj | Site Index | Cond. | Nbhd. | Nbhd. Adj | Notes | | Location Adjustment | | Adj Unit P | Land Value | |
| 1 | 1010 | Single Family | RC | Primary | 40,000 SF | 8.75 | 1.00000 | 5 | 1.00 | 0050 | 1.000 | | | | | 1.0000 | 8.75 | 350,000 |
| 1 | 1010 | Single Family | RC | Residual | 0.156 AC | 35,000.00 | 1.00000 | 5 | 1.00 | 0050 | 1.000 | | | | | 1.0000 | 0.81 | 5,500 |
| Total Card Land Units | | | | | 1.07 AC | Parcel Total Land Area | | | | | 1.07 | Total Land Value | | | | | 355,500 | |

| CONSTRUCTION DETAIL | | | CONSTRUCTION DETAIL (CONTINUED) | | |
|---------------------|------|----------------|---------------------------------|------|-------------|
| Element | Cd | Description | Element | Cd | Description |
| Style | 00 | Gambrel | Bsmt Area | 1064 | |
| Model | 01 | Residential | Bsmt Type | 00 | |
| Grade | 04 | Above Ave | Unfin Area | 0.00 | N/A |
| Stories | 1.9 | | | | |
| Occupancy | 1 | | CONDO DATA | | |
| Exterior Wall 1 | 14 | Wood Shingle | Parcel Id | | C |
| Exterior Wall 2 | | | | | B |
| Roof Structure | 07 | Gambrel | Adjust Type | Code | Description |
| Roof Cover | 03 | Asphalt | Condo Flr | | Factor% |
| Interior Wall 1 | 05 | Drywall | Condo Unit | | |
| Interior Wall 2 | | | COST / MARKET VALUATION | | |
| Interior Floor 1 | 12 | Hardwood | Net Other Adj | | 413,064 |
| Interior Floor 2 | | | Replace Cost | | 14,950 |
| Heat Fuel | 03 | Gas | Year Built | | 428,013 |
| Heat Type | 04 | Forced Air-Duc | Effective Year Built | | 1972 |
| AC Type | 01 | None | Depreciation Code | | 1992 |
| Bedrooms | 3 | | Remodel Rating | | A |
| Full Baths | 2 | | Year Remodeled | | |
| Half Baths | 0 | | Depreciation % | | 29 |
| Extra Fixtures | 0 | | Functional Obsol | | |
| Total Rooms | 6 | | External Obsol | | |
| Bath Style | 02 | Average | Trend Factor | | 1.000 |
| Kitchen Style | 02 | Average | Condition | | |
| Extra Kitchens | 0 | | Condition % | | |
| Fireplaces | 1 | | Percent Good | | 71 |
| Extra Openings | 0 | | Cns Sect Rcnld | | 303,900 |
| Gas Fireplaces | 0 | | Dep % Ovr | | |
| Sq Ft Fin Bsmt | 0 | | Dep Ovr Comment | | |
| FBM Quality | | | Misc Imp Ovr | | |
| Foundation | 06 | Poured Conc | Misc Imp Ovr Comment | | |
| Bsmt Garage | 0 | | Cost to Cure Ovr | | |
| Bsmt Area | 1064 | | Cost to Cure Ovr Comment | | |

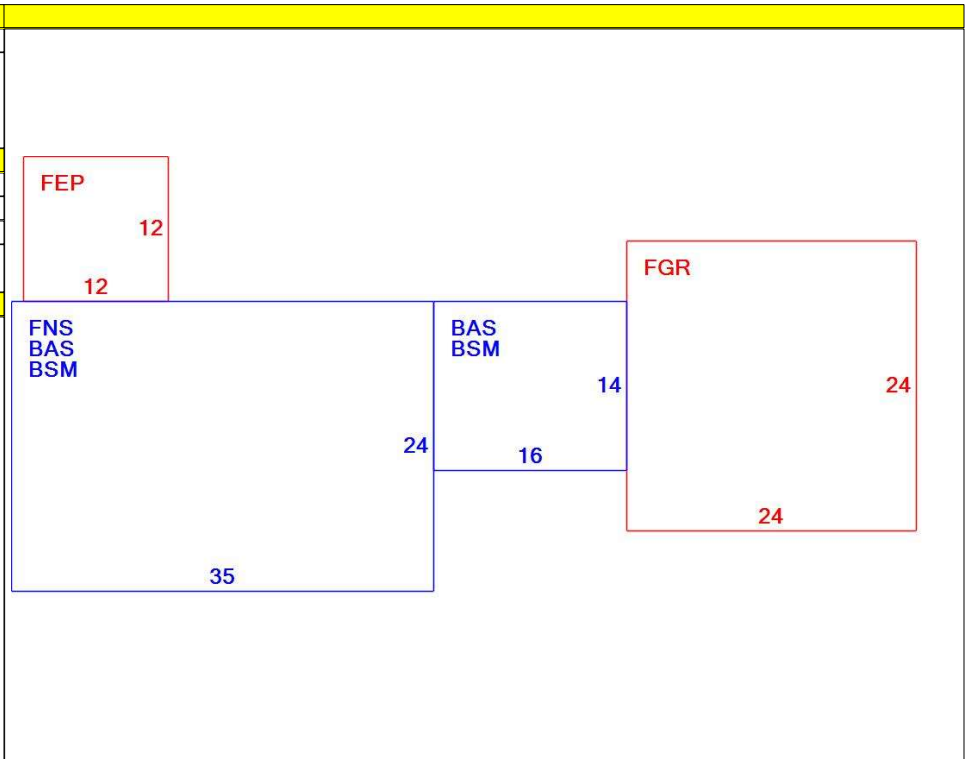

| OB - OUTBUILDING & YARD ITEMS(L) / XF - BUILDING EXTRA FEATURES(B) | | | | | | | | | | |
|--|-------------|-----|-------|------------|--------|----------|------|-------|------------|-------------|
| Code | Description | L/B | Units | Unit Price | Yr Blt | Cond. Cd | % Gd | Grade | Grade Adj. | Appr. Value |
| SHD1 | Shed | L | 100 | 21.00 | 1985 | A | 70 | C | 1.00 | 1,500 |

| BUILDING SUB-AREA SUMMARY SECTION | | | | | | |
|-----------------------------------|-------------------------|-------------|------------|----------|-----------|----------------|
| Code | Description | Living Area | Floor Area | Eff Area | Unit Cost | Undeprec Value |
| BAS | First Floor | 1,064 | 1,064 | 1,064 | 175.85 | 187,101 |
| BSM | Basement | 0 | 1,064 | 213 | 35.20 | 37,455 |
| FEP | Finished Enclosed Porch | 0 | 144 | 86 | 105.02 | 15,123 |
| FGR | Garage | 0 | 576 | 230 | 70.22 | 40,445 |
| FNS | Finished 90% Story | 756 | 840 | 756 | 158.26 | 132,940 |
| Ttl Gross Liv / Lease Area | | 1,820 | 3,688 | 2,349 | | 413,064 |



15 TURKEY RIDGE LN

