

| CURRENT OWNER | | TOPO | UTILITIES | STRT / ROAD | LOCATION | CURRENT ASSESSMENT | | | | | |
|-------------------------|--|---|------------|---|-----------|--------------------|------|-----------|-----------|------------------------|-----------|
| GEORGANTAS KERRY R | | | 0 Water | 0 Cul-De-Sac | 0 Average | Description | Code | Appraised | Assessed | 905 DUXBURY, MA | |
| GEORGANTAS NICHOLAS | | | 0 No Sewer | 0 Paved | 0 Average | RESIDENTL | 1010 | 773,500 | 773,500 | | |
| 35 COLES ORCHARD RD | | SUPPLEMENTAL DATA | | | | RES LAND | 1010 | 517,000 | 517,000 | VISION | |
| DUXBURY MA 02332 | | Alt Prcl ID Scnd Home Tax Class T Tot Fin Area 3280 Total Acres .918 Chapter Lan | | Cyclical 4 Exemption W District Res Exem | | | | | | | |
| GIS ID F_867734_2839448 | | Assoc Pid# | | | | | | Total | 1,290,500 | | 1,290,500 |

| RECORD OF OWNERSHIP | | BK-VOL/PAGE | SALE DATE | Q/U | V/I | SALE PRICE | VC | PREVIOUS ASSESSMENTS (HISTORY) | | | | | |
|-------------------------|--|-------------|------------|-----|-----|------------|----|--------------------------------|-----------|----------|---------|-------|----------|
| GEORGANTAS KERRY R | | 51251 224 | 06-19-2019 | Q | I | 929,000 | 00 | Year | Code | Assessed | Year | Code | Assessed |
| WILKINSON LINDSAY H | | 40176 0119 | 08-01-2011 | U | I | 1 | 1F | 2023 | 1010 | 594,200 | 2022 | 1010 | 545,800 |
| WILKINSON GEOFFREY C JR | | 35563 0324 | 02-01-2008 | Q | I | 816,000 | 00 | | 1010 | 554,800 | 2021 | 1010 | 340,100 |
| CHASE BROOKS | | 27983 0071 | 04-16-2004 | U | I | 687,250 | 1 | | | | | | |
| WUENNEMANN RONALD B | | 16837 0282 | 11-20-1998 | Q | I | 425,000 | 00 | Total | 1,149,000 | Total | 898,400 | Total | 806,900 |

| EXEMPTIONS | | | OTHER ASSESSMENTS | | | | | |
|------------|------|-------------|-------------------|------|-------------|--------|--------|----------|
| Year | Code | Description | Amount | Code | Description | Number | Amount | Comm Int |
| Total | | | 0.00 | | | | | |

| ASSESSING NEIGHBORHOOD | | | | |
|------------------------|-----------|---|---------|-------|
| Nbhd | Nbhd Name | B | Tracing | Batch |
| 0060 | | | | |

| APPRAISED VALUE SUMMARY | | | | | | | | | |
|-------------------------------|--|--|--|--|--|--|--|--|-----------|
| Appraised Bldg. Value (Card) | | | | | | | | | 773,500 |
| Appraised Xf (B) Value (Bldg) | | | | | | | | | 0 |
| Appraised Ob (B) Value (Bldg) | | | | | | | | | 0 |
| Appraised Land Value (Bldg) | | | | | | | | | 517,000 |
| Special Land Value | | | | | | | | | 0 |
| Total Appraised Parcel Value | | | | | | | | | 1,290,500 |
| Valuation Method | | | | | | | | | C |
| Total Appraised Parcel Value | | | | | | | | | 1,290,500 |

| BUILDING PERMIT RECORD | | | | | | | | | | VISIT / CHANGE HISTORY | | | | | |
|------------------------|------------|------|---------------|--------|-----------|--------|-----------|--------------------------------|--|------------------------|-----|------|----|----|------------------|
| Permit Id | Issue Date | Type | Description | Amount | Insp Date | % Comp | Date Comp | Comments | | Date | Id | Type | Is | Cd | Purpose/Result |
| QPO-23-16 | 06-06-2023 | MN | Maintenance | 3,600 | | 100 | | Weatherization and air sealing | | 05-06-2020 | SJD | 9 | | 20 | Field Review |
| 89 | 08-09-2007 | MN | Maintenance | 13,079 | | 100 | | REPL 8 WINDOWS | | 04-12-2013 | VGS | | | 20 | Field Review |
| 43 | 05-05-2006 | MS | Miscellaneous | 1,000 | | 100 | | REPL 1 WINDOWS | | 07-14-2009 | KP | | 1 | 00 | Measure & Listed |
| 19990513 | 11-10-1999 | MN | Maintenance | 5,000 | | 100 | | STRIP AND REROOF | | | | | | | |

| LAND LINE VALUATION SECTION | | | | | | | | | | | | | | | | |
|-----------------------------|----------|---------------|------|-----------|------------|------------|------------------------|------------|-------|-------|-----------|-------|---------------------|------------|------------|---------|
| B | Use Code | Description | Zone | Land Type | Land Units | Unit Price | Size Adj | Site Index | Cond. | Nbhd. | Nbhd. Adj | Notes | Location Adjustment | Adj Unit P | Land Value | |
| 1 | 1010 | Single Family | RC | Primary | 40,053 SF | 8.75 | 1.00000 | 5 | 1.00 | 0060 | 1.341 | | V110 | 1.1000 | 12.91 | 517,000 |
| Total Card Land Units | | | | | 0.92 | AC | Parcel Total Land Area | | | | | 0.92 | Total Land Value | | | 517,000 |

| CONSTRUCTION DETAIL | | | CONSTRUCTION DETAIL (CONTINUED) | | |
|---------------------|------|--------------|---------------------------------|------|-------------|
| Element | Cd | Description | Element | Cd | Description |
| Style | 03 | Colonial | Bsmt Area | 1424 | |
| Model | 01 | Residential | Bsmt Type | 04 | |
| Grade | 07 | Very Good | Unfin Area | 0.00 | Full |
| Stories | 2 | | CONDO DATA | | |
| Occupancy | 1 | | Parcel Id | | C |
| Exterior Wall 1 | 11 | Clapboard | | | B |
| Exterior Wall 2 | | | | | S |
| Roof Structure | 07 | Gambrel | Adjust Type | Code | Description |
| Roof Cover | 10 | Wood Shingle | Condo Flr | | |
| Interior Wall 1 | 05 | Drywall | Condo Unit | | |
| Interior Wall 2 | | | COST / MARKET VALUATION | | |
| Interior Floor 1 | 12 | Hardwood | Net Other Adj | | 868,594 |
| Interior Floor 2 | | | Replace Cost | | 74,720 |
| Heat Fuel | 02 | Oil | Year Built | | 1986 |
| Heat Type | 05 | Hot Water | Effective Year Built | | 2003 |
| AC Type | 03 | Central | Depreciation Code | | G |
| Bedrooms | 4 | | Remodel Rating | | |
| Full Baths | 3 | | Year Remodeled | | |
| Half Baths | 1 | | Depreciation % | | 18 |
| Extra Fixtures | 2 | | Functional Obsol | | |
| Total Rooms | 9 | | External Obsol | | |
| Bath Style | 02 | Average | Trend Factor | | 1.000 |
| Kitchen Style | 03 | Modern | Condition | | |
| Extra Kitchens | 0 | | Condition % | | |
| Fireplaces | 1 | | Percent Good | | 82 |
| Extra Openings | 0 | | Cns Sect Rcnld | | 773,500 |
| Gas Fireplaces | 0 | | Dep % Ovr | | |
| Sq Ft Fin Bsmt | 1064 | | Dep Ovr Comment | | |
| FBM Quality | 05 | Living Area | Misc Imp Ovr | | |
| Foundation | 06 | Poured Conc | Misc Imp Ovr Comment | | |
| Bsmt Garage | 0 | | Cost to Cure Ovr | | |
| Bsmt Area | 1424 | | Cost to Cure Ovr Comment | | |

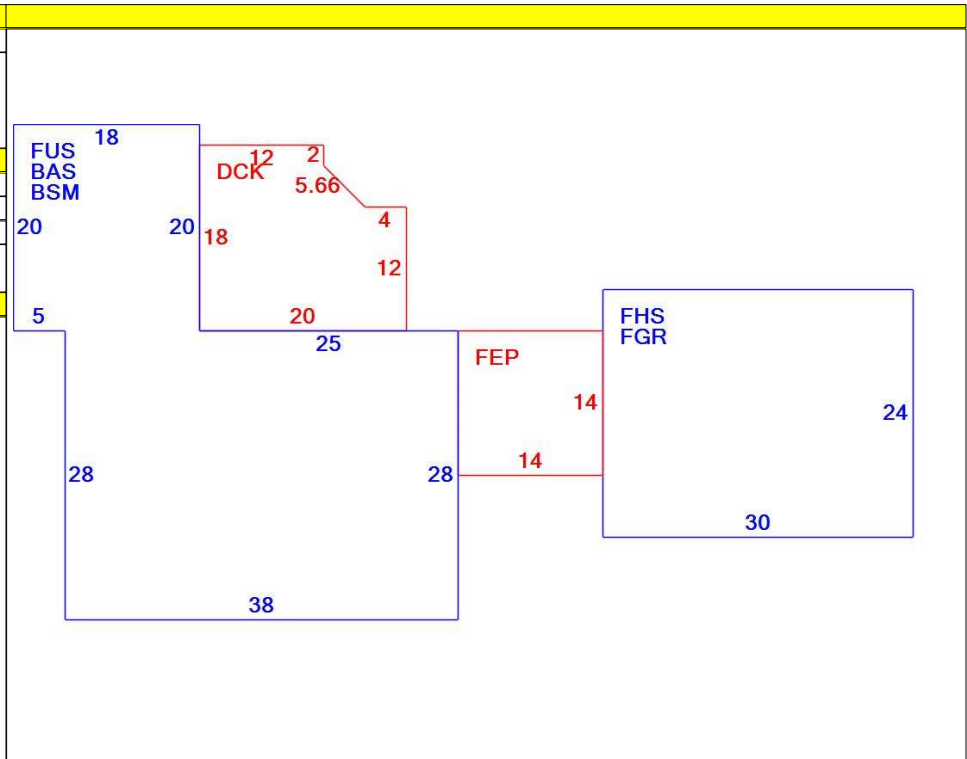

| OB - OUTBUILDING & YARD ITEMS(L) / XF - BUILDING EXTRA FEATURES(B) | | | | | | | | | | |
|--|-------------|-----|-------|------------|--------|----------|------|-------|------------|-------------|
| Code | Description | L/B | Units | Unit Price | Yr Blt | Cond. Cd | % Gd | Grade | Grade Adj. | Appr. Value |
| | | | | | | | | | | |

| BUILDING SUB-AREA SUMMARY SECTION | | | | | | |
|-----------------------------------|-------------------------|-------------|------------|----------|-----------|----------------|
| Code | Description | Living Area | Floor Area | Eff Area | Unit Cost | Undeprec Value |
| BAS | First Floor | 1,424 | 1,424 | 1,424 | 220.96 | 314,647 |
| BSM | Basement | 0 | 1,424 | 285 | 44.22 | 62,974 |
| DCK | Deck | 0 | 320 | 32 | 22.10 | 7,071 |
| FEP | Finished Enclosed Porch | 0 | 196 | 118 | 133.03 | 26,073 |
| FGR | Garage | 0 | 720 | 288 | 88.38 | 63,636 |
| FHS | Finished Half Story | 360 | 720 | 360 | 110.48 | 79,546 |
| FUS | Finished Upper Story | 1,424 | 1,424 | 1,424 | 220.96 | 314,647 |
| Ttl Gross Liv / Lease Area | | 3,208 | 6,228 | 3,931 | | 868,594 |

