

| CURRENT OWNER | | TOPO | | UTILITIES | | STRT / ROAD | | LOCATION | | CURRENT ASSESSMENT | | | | 905 DUXBURY, MA VISION | | | | | | | | | |
|---|------------|--------------------------|-------------|-------------------|------------|--------------|------------------------|------------|---------|--------------------|-----------|---|------------------|---|---------------------|--------------------------------|------------------|------------|---------|---------|--|---------|--|
| PITTORE DANIEL PITTORE SHIRLEY M 107 KINGS TOWN WAY DUXBURY MA 02332 | | | | 0 | Water | 0 | Arterial | 0 | Average | Description | Code | Appraised | Assessed | | | | | | | | | | |
| | | | | 0 | No Sewer | 0 | Paved | 0 | Average | RESIDNTL | 1010 | 259,100 | 259,100 | | | | | | | | | | |
| | | SUPPLEMENTAL DATA | | | | 0 | Heavy | | | | RES LAND | 1010 | 353,900 | | 353,900 | | | | | | | | |
| | | Alt Prcl ID | | Cyclical | | 2 | | | | RESIDNTL | 1010 | 36,700 | 36,700 | | | | | | | | | | |
| | | Scnd Home | | Exemption | | | | | | Total | | 649,700 | 649,700 | | | | | | | | | | |
| | | Tax Class T | | W | | District | | | | | | | | | | | | | | | | | |
| | | Tot Fin Area 1696 | | Res Exem | | | | | | | | | | | | | | | | | | | |
| | | Total Acres 1.028 | | Assoc Pid# | | | | | | | | | | | | | | | | | | | |
| | | Chapter Lan | | | | | | | | | | | | | | | | | | | | | |
| | | GIS ID F_864009_2834131 | | | | | | | | | | | | | | | | | | | | | |
| RECORD OF OWNERSHIP | | | | BK-VOL/PAGE | | SALE DATE | | Q/U V/I | | SALE PRICE | | VC | | PREVIOUS ASSESSMENTS (HISTORY) | | | | | | | | | |
| PITTORE DANIEL HILSABECK JOHN R JR | | | | 16152 | 0239 | 05-01-1998 | Q | I | 202,000 | 00 | | | Year | Code | Assessed | Year | Code | Assessed | | | | | |
| | | | | 4033 | 0101 | 09-28-1993 | Q | I | 195,000 | 00 | 2023 | 1010 | 192,900 | 2022 | 1010 | 163,000 | 2021 | 1010 | 162,700 | | | | |
| | | | | | | | | | | | | | 1010 | 368,000 | | 1010 | 303,300 | | | | | | |
| | | | | | | | | | | | | | 1010 | 20,200 | | 1010 | 20,200 | | | | | | |
| | | | | Total | | | | | | | | Total | | 581,100 | Total | | 486,500 | Total | | 435,700 | | | |
| EXEMPTIONS | | | | OTHER ASSESSMENTS | | | | | | | | This signature acknowledges a visit by a Data Collector or Assessor | | | | | | | | | | | |
| Year | Code | Description | | Amount | | Code | Description | | Number | Amount | | Comm Int | | | | | | | | | | | |
| | | | | | | | | | | | | | | | | | | | | | | | |
| | | | | Total | | 0.00 | | | | | | | | | | APPRAISED VALUE SUMMARY | | | | | | | |
| | | | | | | | | | | | | | | Appraised Bldg. Value (Card) | | | | | | | | 259,100 | |
| | | | | | | | | | | | | | | Appraised Xf (B) Value (Bldg) | | | | | | | | 0 | |
| | | | | | | | | | | | | | | Appraised Ob (B) Value (Bldg) | | | | | | | | 36,700 | |
| | | | | | | | | | | | | | | Appraised Land Value (Bldg) | | | | | | | | 353,900 | |
| | | | | | | | | | | | | | | Special Land Value | | | | | | | | 0 | |
| | | | | | | | | | | | | | | Total Appraised Parcel Value | | | | | | | | 649,700 | |
| | | | | | | | | | | | | | | Valuation Method | | | | | | | | C | |
| | | | | | | | | | | | | | | Total Appraised Parcel Value | | | | | | | | 649,700 | |
| BUILDING PERMIT RECORD | | | | | | | | | | | | VISIT / CHANGE HISTORY | | | | | | | | | | | |
| Permit Id | Issue Date | Type | Description | Amount | Insp Date | % Comp | Date Comp | Comments | | | | Date | Id | Type | Is | Cd | Purpose/Result | | | | | | |
| | | | | | | | | | | | | 04-12-2013 | VGS | | | 20 | Field Review | | | | | | |
| | | | | | | | | | | | | 08-30-2007 | BSB | | 1 | 00 | Measure & Listed | | | | | | |
| LAND LINE VALUATION SECTION | | | | | | | | | | | | | | | | | | | | | | | |
| B | Use Code | Description | Zone | Land Type | Land Units | Unit Price | Size Adj | Site Index | Cond. | Nbhd. | Nbhd. Adj | Notes | | | Location Adjustment | | Adj Unit P | Land Value | | | | | |
| 1 | 1010 | Single Family | RC | Primary | 40,000 | SF 8.75 | 1.00000 | 5 | 1.00 | 0050 | 1.000 | | | | | | 1.0000 | 8.75 | 350,000 | | | | |
| 1 | 1010 | Single Family | RC | Residual | 0.112 | AC 35,000.00 | 1.00000 | 5 | 1.00 | 0050 | 1.000 | | | | | | 1.0000 | 0.80 | 3,900 | | | | |
| Total Card Land Units | | | | | 1.03 | AC | Parcel Total Land Area | | | | | 1.03 | Total Land Value | | | | | 353,900 | | | | | |

| CONSTRUCTION DETAIL | | | CONSTRUCTION DETAIL (CONTINUED) | | |
|---------------------|------|--------------|---------------------------------|------|-------------|
| Element | Cd | Description | Element | Cd | Description |
| Style | 04 | Cape Cod | Bsmt Area | 1003 | |
| Model | 01 | Residential | Bsmt Type | 04 | |
| Grade | 03 | Average | Unfin Area | 0.00 | Full |
| Stories | 1.75 | | | | |
| Occupancy | 1 | | CONDO DATA | | |
| Exterior Wall 1 | 14 | Wood Shingle | Parcel Id | | C |
| Exterior Wall 2 | | | | | B |
| Roof Structure | 03 | Gable | Adjust Type | Code | Description |
| Roof Cover | 03 | Asphalt | Condo Flr | | |
| Interior Wall 1 | 05 | Drywall | Condo Unit | | |
| Interior Wall 2 | | | COST / MARKET VALUATION | | |
| Interior Floor 1 | 12 | Hardwood | Net Other Adj | | 357,075 |
| Interior Floor 2 | | | Replace Cost | | 13,000 |
| Heat Fuel | 02 | Oil | Year Built | | 370,075 |
| Heat Type | 05 | Hot Water | Effective Year Built | | 1963 |
| AC Type | 01 | None | Depreciation Code | | 1991 |
| Bedrooms | 3 | | Remodel Rating | | A |
| Full Baths | 2 | | Year Remodeled | | |
| Half Baths | 0 | | Depreciation % | | 30 |
| Extra Fixtures | 0 | | Functional Obsol | | |
| Total Rooms | 6 | | External Obsol | | |
| Bath Style | 02 | Average | Trend Factor | | 1.000 |
| Kitchen Style | 02 | Average | Condition | | |
| Extra Kitchens | 0 | | Condition % | | |
| Fireplaces | 1 | | Percent Good | | 70 |
| Extra Openings | 0 | | Cns Sect Rcnld | | 259,100 |
| Gas Fireplaces | 0 | | Dep % Ovr | | |
| Sq Ft Fin Bsmt | 0 | | Dep Ovr Comment | | |
| FBM Quality | | | Misc Imp Ovr | | |
| Foundation | 06 | Poured Conc | Misc Imp Ovr Comment | | |
| Bsmt Garage | 0 | | Cost to Cure Ovr | | |
| Bsmt Area | 1003 | | Cost to Cure Ovr Comment | | |

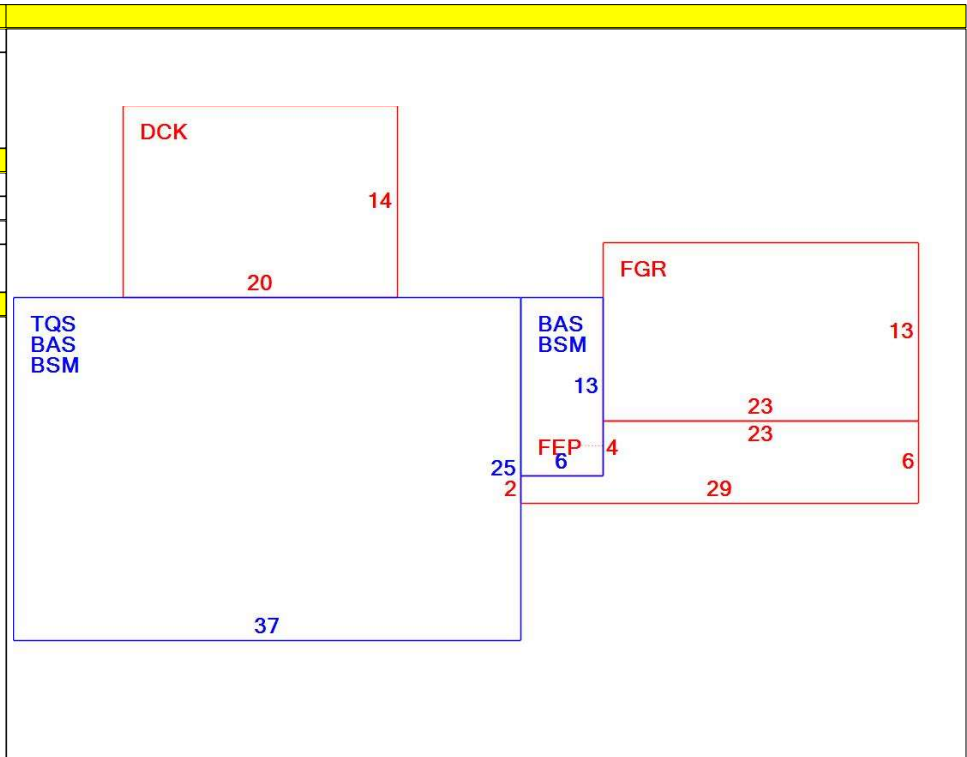

OB - OUTBUILDING & YARD ITEMS(L) / XF - BUILDING EXTRA FEATURES(B)

| Code | Description | L/B | Units | Unit Price | Yr Blt | Cond. Cd | % Gd | Grade | Grade Adj. | Appr. Value |
|------|----------------|-----|-------|------------|--------|----------|------|-------|------------|-------------|
| SPL1 | Ing Pool - Ave | L | 800 | 64.00 | 1980 | A | 70 | C | 1.00 | 35,800 |
| SHD1 | Shed | L | 64 | 21.00 | 1995 | A | 70 | C | 1.00 | 900 |

BUILDING SUB-AREA SUMMARY SECTION

| Code | Description | Living Area | Floor Area | Eff Area | Unit Cost | Undeprec Value |
|----------------------------|-------------------------|-------------|------------|----------|-----------|----------------|
| BAS | First Floor | 1,003 | 1,003 | 1,003 | 167.17 | 167,672 |
| BSM | Basement | 0 | 1,003 | 201 | 33.50 | 33,601 |
| DCK | Deck | 0 | 280 | 28 | 16.72 | 4,681 |
| FEP | Finished Enclosed Porch | 0 | 150 | 90 | 100.30 | 15,045 |
| FGR | Garage | 0 | 299 | 120 | 67.09 | 20,060 |
| TQS | Three Quarter Story | 694 | 925 | 694 | 125.42 | 116,016 |
| Ttl Gross Liv / Lease Area | | 1,697 | 3,660 | 2,136 | | 357,075 |



107 KINGS TOWN WAY

