

CURRENT OWNER		TOPO	UTILITIES	STRT / ROAD	LOCATION	CURRENT ASSESSMENT					
SURETTE PAULA J TT			0 Water	0 Subdivision	0 Average	Description	Code	Appraised	Assessed	905 DUXBURY, MA	
PAULA J SURETTE TRUST			0 No Sewer	0 Paved	0 Average	RESIDNTL	1010	330,500	330,500		
40 TROUT FARM LN		SUPPLEMENTAL DATA				RES LAND	1010	272,200	272,200	VISION	
DUXBURY MA 02332		Alt Prcl ID Scnd Home Tax Class T Tot Fin Area 1816 Total Acres .26 Chapter Lan		Cyclical 2 Exemption W District Res Exem							
GIS ID F_862447_2834518		Assoc Pid#						Total	602,700		602,700
								Total	602,700		602,700

RECORD OF OWNERSHIP		BK-VOL/PAGE	SALE DATE	Q/U	V/I	SALE PRICE	VC	PREVIOUS ASSESSMENTS (HISTORY)													
SURETTE PAULA J TT		47490 0082	09-21-2016	U	I	100	1A	Year	Code	Assessed	Year	Code	Assessed	Year	Code	Assessed					
BUTLER WILLIAM B		15366 0234	07-31-1997	U	I	100	1	2023	1010	287,900	2022	1010	259,400	2021	1010	230,400					
SURETTE PAULA J		13411 0230	02-03-1995	Q	I	197,500	00		1010	281,600		1010	231,600		1010	202,900					
TWO-COUNTY		5292 0298	06-29-1993	U	V	1	1	Total									569,500	Total	491,000	Total	433,300

EXEMPTIONS			OTHER ASSESSMENTS						
Year	Code	Description	Amount	Code	Description	Number	Amount	Comm Int	
Total								0.00	

ASSESSING NEIGHBORHOOD				
Nbhd	Nbhd Name	B	Tracing	Batch
0050				

APPRAISED VALUE SUMMARY															
Appraised Bldg. Value (Card)														330,500	
Appraised Xf (B) Value (Bldg)														0	
Appraised Ob (B) Value (Bldg)														0	
Appraised Land Value (Bldg)														272,200	
Special Land Value														0	
Total Appraised Parcel Value														602,700	
Valuation Method														C	
Total Appraised Parcel Value														602,700	

BUILDING PERMIT RECORD										VISIT / CHANGE HISTORY					
Permit Id	Issue Date	Type	Description	Amount	Insp Date	% Comp	Date Comp	Comments		Date	Id	Type	Is	Cd	Purpose/Result
QPO-22-32 13369	12-27-2022 08-12-1994	MN NC	Maintenance New Construct	2,668 115,000		100 100	12-27-2022	AIR SEALING/CELLULOSE INS 18X30 ATT TOWN HOUSE		10-02-2019 04-12-2013 10-09-2007	SJD VGS BSB	4		20 20 00	Field Review Field Review Measure & Listed

LAND LINE VALUATION SECTION																	
B	Use Code	Description	Zone	Land Type	Land Units	Unit Price	Size Adj	Site Index	Cond.	Nbhd.	Nbhd. Adj	Notes	Location Adjustment	Adj Unit P	Land Value		
1	1010	Single Family	PD	Primary	11,370 SF	23.94	1.00000	5	1.00	0050	1.000	EASMT "B" DV -17500 REMOV		1.0000	23.94	272,200	
Total Card Land Units					0.26 AC	Parcel Total Land Area					0.26	Total Land Value					272,200

CONSTRUCTION DETAIL			CONSTRUCTION DETAIL (CONTINUED)		
Element	Cd	Description	Element	Cd	Description
Style	07	Contemporary	Bsmt Area	1060	
Model	01	Residential	Bsmt Type	00	N/A
Grade	05	Ave/Good	Unfin Area	0.00	
Stories	2				
Occupancy	1				
Exterior Wall 1	14	Wood Shingle			
Exterior Wall 2					
Roof Structure	03	Gable			
Roof Cover	03	Asphalt			
Interior Wall 1	05	Drywall			
Interior Wall 2					
Interior Floor 1	12	Hardwood			
Interior Floor 2					
Heat Fuel	02	Oil			
Heat Type	05	Hot Water			
AC Type	03	Central			
Bedrooms	2				
Full Baths	2				
Half Baths	1				
Extra Fixtures	0				
Total Rooms	5				
Bath Style	02	Average			
Kitchen Style	02	Average			
Extra Kitchens	0				
Fireplaces	1				
Extra Openings	0				
Gas Fireplaces	0				
Sq Ft Fin Bsmt	0				
FBM Quality					
Foundation	06	Poured Conc			
Bsmt Garage	0				
Bsmt Area	1060				

CONDO DATA				
Parcel Id		C	Own	
			B	S
Adjust Type	Code	Description	Factor%	
Condo Flr				
Condo Unit				

COST / MARKET VALUATION				
Net Other Adj			359,777	
Replace Cost			20,150	
Year Built			379,928	
Effective Year Built			1995	
Depreciation Code			2008	
Remodel Rating			G	
Year Remodeled				
Depreciation %			13	
Functional Obsol				
External Obsol				
Trend Factor			1.000	
Condition				
Condition %				
Percent Good			87	
Cns Sect Rcnld			330,500	
Dep % Ovr				
Dep Ovr Comment				
Misc Imp Ovr				
Misc Imp Ovr Comment				
Cost to Cure Ovr				
Cost to Cure Ovr Comment				

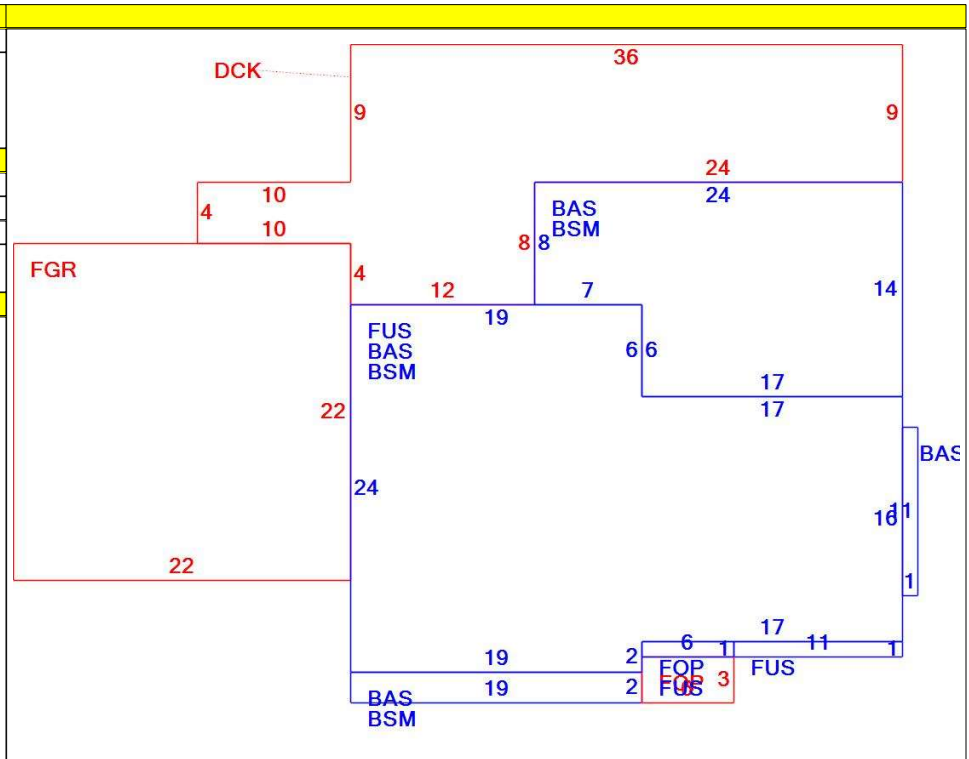

OB - OUTBUILDING & YARD ITEMS(L) / XF - BUILDING EXTRA FEATURES(B)										
Code	Description	L/B	Units	Unit Price	Yr Blt	Cond. Cd	% Gd	Grade	Grade Adj.	Appr. Value

BUILDING SUB-AREA SUMMARY SECTION						
Code	Description	Living Area	Floor Area	Eff Area	Unit Cost	Undeprec Value
BAS	First Floor	1,071	1,071	1,071	158.35	169,596
BSM	Basement	0	1,060	212	31.67	33,571
DCK	Deck	0	460	46	15.84	7,284
FGR	Garage	0	484	194	63.47	30,720
FOP	Open Porch	0	24	4	26.39	633
FUS	Finished Upper Story	745	745	745	158.35	117,973
Ttl Gross Liv / Lease Area		1,816	3,844	2,272		359,777



40 TROUT FARM LN

