

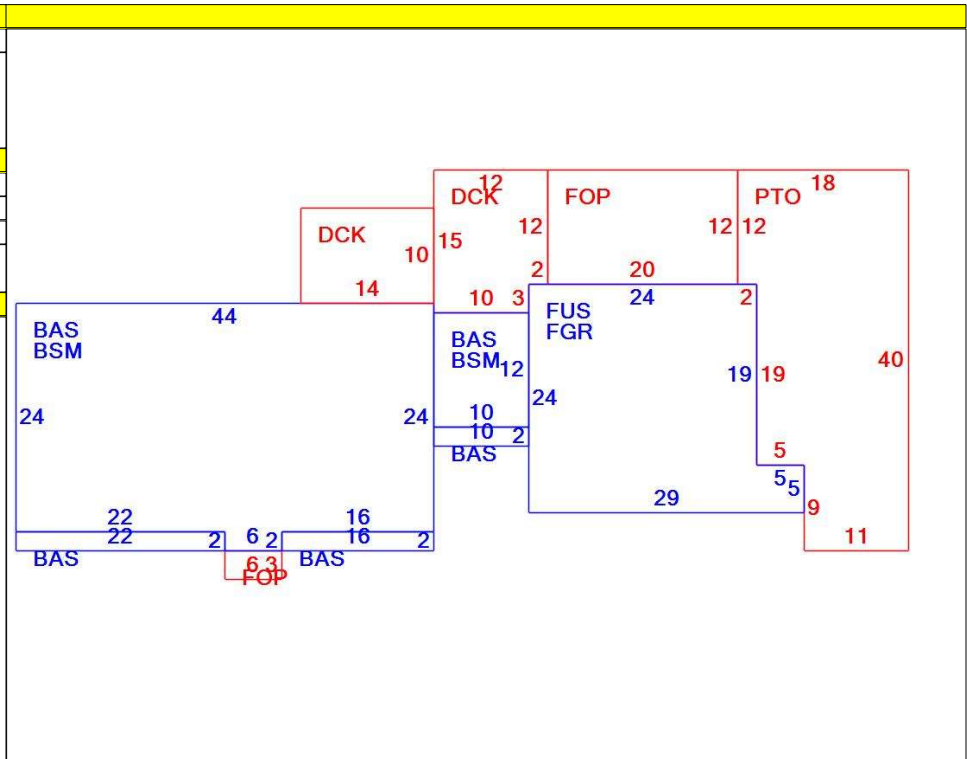

CONSTRUCTION DETAIL			CONSTRUCTION DETAIL (CONTINUED)		
Element	Cd	Description	Element	Cd	Description
Style	08	Raised Ranch	Bsmt Area	1056	
Model	01	Residential	Bsmt Type	03	
Grade	05	Ave/Good	Unfin Area	0.00	Partial
Stories	1				
Occupancy	1		<b>CONDO DATA</b>		
Exterior Wall 1	14	Wood Shingle	Parcel Id		C
Exterior Wall 2					B
Roof Structure	03	Gable	Adjust Type	Code	Description
Roof Cover	03	Asphalt	Condo Flr		Factor%
Interior Wall 1	05	Drywall	Condo Unit		
Interior Wall 2			<b>COST / MARKET VALUATION</b>		
Interior Floor 1	12	Hardwood	Net Other Adj		478,685
Interior Floor 2			Replace Cost		37,960
Heat Fuel	02	Oil	Year Built		516,646
Heat Type	05	Hot Water	Effective Year Built		1970
AC Type	03	Central	Depreciation Code		2002
Bedrooms	3		Remodel Rating		VG
Full Baths	2		Year Remodeled		
Half Baths	1		Depreciation %		19
Extra Fixtures	4		Functional Obsol		
Total Rooms	6		External Obsol		
Bath Style	02	Average	Trend Factor		1.000
Kitchen Style	02	Average	Condition		
Extra Kitchens	0		Condition %		
Fireplaces	1		Percent Good		81
Extra Openings	1		Cns Sect Rcnd		418,500
Gas Fireplaces	0		Dep % Ovr		
Sq Ft Fin Bsmt	384		Dep Ovr Comment		
FBM Quality	05	Living Area	Misc Imp Ovr		
Foundation	06	Poured Conc	Misc Imp Ovr Comment		
Bsmt Garage	0		Cost to Cure Ovr		
Bsmt Area	1056		Cost to Cure Ovr Comment		



OB - OUTBUILDING & YARD ITEMS(L) / XF - BUILDING EXTRA FEATURES(B)										
Code	Description	L/B	Units	Unit Price	Yr Blt	Cond. Cd	% Gd	Grade	Grade Adj.	Appr. Value
SPL2	Ing Pool-Good	L	820	89.00	2010	G	85	C	1.00	62,000
PHS	Pool House	L	484	143.00	2011	G	85	C	1.00	58,800
SHD1	Shed	L	320	21.00	2010	G	85	C	1.00	5,700
SHD1	Shed	L	192	21.00	2017	E	100	B	1.50	6,000

BUILDING SUB-AREA SUMMARY SECTION						
Code	Description	Living Area	Floor Area	Eff Area	Unit Cost	Undeprec Value
BAS	First Floor	1,284	1,284	1,284	194.27	249,445
BSM	Basement	0	1,188	238	38.92	46,237
DCK	Deck	0	314	31	19.18	6,022
FGR	Garage	0	601	240	77.58	46,625
FOP	Open Porch	0	258	39	29.37	7,577
FUS	Finished Upper Story	601	601	601	194.27	116,757
PTO	Patio	0	619	31	9.73	6,022
Ttl Gross Liv / Lease Area		1,885	4,865	2,464		478,685

