

CURRENT OWNER		TOPO		UTILITIES		STRT / ROAD		LOCATION		CURRENT ASSESSMENT				905 DUXBURY, MA VISION					
ELAINE M BOC TRUSTEE ELAINE M BOC TRUST 10 JEREMIAH DR DUXBURY MA 02332		0	Water	0	Cul-De-Sac	0	Average	Description	Code	Appraised	Assessed	RESIDNTL 1010 330,900 330,900 RES LAND 1010 487,100 487,100 RESIDNTL 1010 34,000 34,000							
		0	Septic	0	Paved	0	Average												
		SUPPLEMENTAL DATA		Alt Prcl ID Scnd Home Tax Class T Tot Fin Area 1968 Total Acres .92 Chapter Lan GIS ID F_868904_2851587		Cyclical Exemption W District Res Exem 3		Assoc Pid#		Total 852,000 852,000									
RECORD OF OWNERSHIP		BK-VOL/PAGE		SALE DATE		Q/U V/I		SALE PRICE		VC		PREVIOUS ASSESSMENTS (HISTORY)							
ELAINE M BOC TRUSTEE		51613	45	09-09-2019	U	I	100	1A	Year	Code	Assessed	Year	Code	Assessed	Year	Code	Assessed		
BOC ELAINE MARIE		17041	0136	01-13-1999	U	I	1	1F	2023	1010	289,900	2022	1010	262,500	2021	1010	234,100		
BOC JOHN F		16760	0093	10-30-1998	U	I	1	1F		1010	475,900		1010	401,600		1010	363,200		
BOC ELAINE MARIE		13078	0261	08-11-1994	U	I	1	1F		1010	17,500		1010	17,500		1010	17,500		
		Total								783,300		Total		681,600		Total		614,800	
EXEMPTIONS				OTHER ASSESSMENTS				This signature acknowledges a visit by a Data Collector or Assessor											
Year	Code	Description		Amount	Code	Description	Number	Amount	Comm Int	APPRAISED VALUE SUMMARY									
				Total	0.00					Appraised Bldg. Value (Card) 330,900									
ASSESSING NEIGHBORHOOD												Appraised Xf (B) Value (Bldg) 0							
Nbhd		Nbhd Name		B	Tracing		Batch		Appraised Ob (B) Value (Bldg) 34,000										
0070									Appraised Land Value (Bldg) 487,100										
NOTES																			
												Special Land Value 0							
												Total Appraised Parcel Value 852,000							
												Valuation Method C							
												Total Appraised Parcel Value 852,000							
BUILDING PERMIT RECORD												VISIT / CHANGE HISTORY							
Permit Id	Issue Date	Type	Description	Amount	Insp Date	% Comp	Date Comp	Comments				Date	Id	Type	Is	Cd	Purpose/Result		
13195	05-17-1994	NC	New Construct	30,000	09-18-1995	100		60X120 TENNIS CT				04-12-2013	VGS			20	Field Review		
											01-24-2008	BSB			01	Measure - No Entry			
LAND LINE VALUATION SECTION																			
B	Use Code	Description	Zone	Land Type	Land Units	Unit Price	Size Adj	Site Index	Cond.	Nbhd.	Nbhd. Adj	Notes			Location Adjustment		Adj Unit P	Land Value	
1	1010	Single Family	PD	Primary	40,075	SF	8.75	1.00000	5	1.00	0070	1.389				1.0000	12.15	487,100	
Total Card Land Units					0.92	AC	Parcel Total Land Area					0.92	Total Land Value					487,100	

CONSTRUCTION DETAIL			CONSTRUCTION DETAIL (CONTINUED)		
Element	Cd	Description	Element	Cd	Description
Style	07	Contemporary	Bsmt Area	1488	
Model	01	Residential	Bsmt Type	04	
Grade	06	Good	Unfin Area	0.00	Full
Stories	2				
Occupancy	1				
Exterior Wall 1	11	Clapboard			
Exterior Wall 2					
Roof Structure	02	Shed			
Roof Cover	03	Asphalt			
Interior Wall 1	05	Drywall			
Interior Wall 2					
Interior Floor 1	12	Hardwood			
Interior Floor 2					
Heat Fuel	02	Oil			
Heat Type	05	Hot Water			
AC Type	01	None			
Bedrooms	3				
Full Baths	2				
Half Baths	1				
Extra Fixtures	1				
Total Rooms	6				
Bath Style	02	Average			
Kitchen Style	02	Average			
Extra Kitchens	0				
Fireplaces	1				
Extra Openings	0				
Gas Fireplaces	0				
Sq Ft Fin Bsmt	336				
FBM Quality	04	Above Average			
Foundation	06	Poured Conc			
Bsmt Garage	2				
Bsmt Area	1488				

CONDO DATA				
Parcel Id		C	Owne	
			B	S
Adjust Type	Code	Description	Factor%	
Condo Flr				
Condo Unit				

COST / MARKET VALUATION				
Net Other Adj			380,682	
Replace Cost			38,135	
Year Built			1978	
Effective Year Built			2000	
Depreciation Code			G	
Remodel Rating				
Year Remodeled				
Depreciation %			21	
Functional Obsol				
External Obsol				
Trend Factor		1.000		
Condition				
Condition %				
Percent Good			79	
Cns Sect Rcnld			330,900	
Dep % Ovr				
Dep Ovr Comment				
Misc Imp Ovr				
Misc Imp Ovr Comment				
Cost to Cure Ovr				
Cost to Cure Ovr Comment				

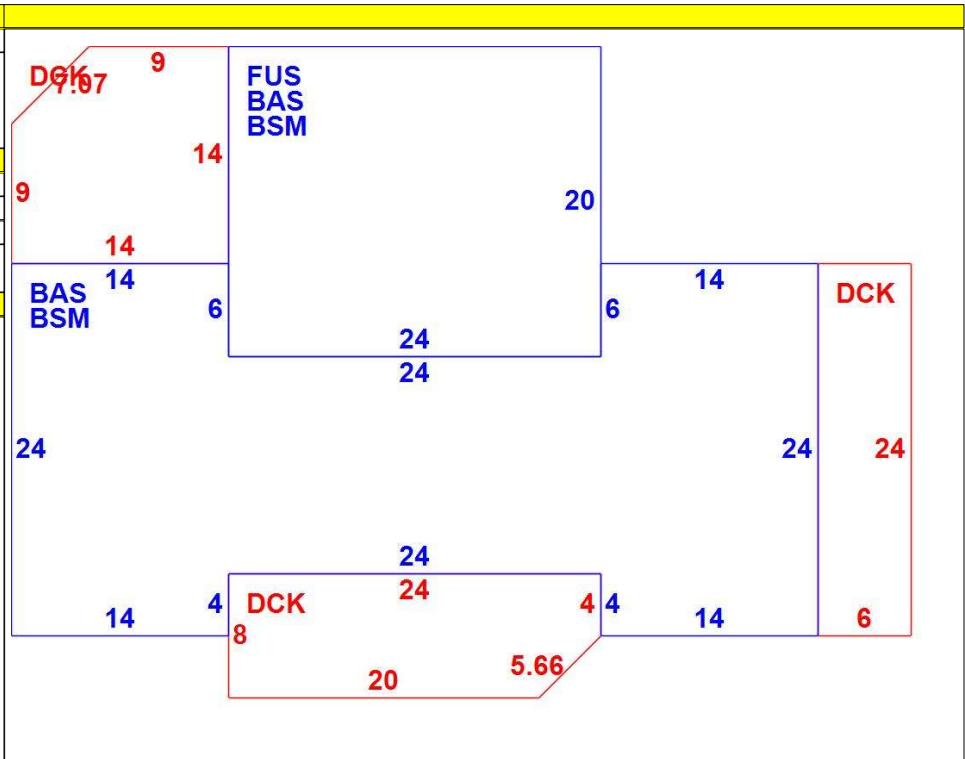

OB - OUTBUILDING & YARD ITEMS(L) / XF - BUILDING EXTRA FEATURES(B)

Code	Description	L/B	Units	Unit Price	Yr Blt	Cond. Cd	% Gd	Grade	Grade Adj.	Appr. Value
TEN	Tennis Court	L	1	48500.00	1995	A	70	C	1.00	34,000

BUILDING SUB-AREA SUMMARY SECTION

Code	Description	Living Area	Floor Area	Eff Area	Unit Cost	Undeprec Value
BAS	First Floor	1,488	1,488	1,488	164.30	244,478
BSM	Basement	0	1,488	298	32.90	48,961
DCK	Deck	0	512	51	16.37	8,379
FUS	Finished Upper Story	480	480	480	164.30	78,864
Ttl Gross Liv / Lease Area		1,968	3,968	2,317		380,682



10 JEREMIAH DR

