

| CURRENT OWNER | | TOPO | UTILITIES | STRT / ROAD | LOCATION | CURRENT ASSESSMENT | | | | | |
|---|--|--|-----------|----------------------|----------|--------------------|---------|-------------|------|-----------|----------|
| STRAVIN MICHAEL C STRAVIN TRISHA 46 WEST ST DUXBURY MA 02332 | | 0 | Water | 0 | Arterial | 0 | Average | Description | Code | Appraised | Assessed |
| | | 0 | No Sewer | 0 | Paved | 0 | Average | RESIDNTL | 1010 | 393,700 | 393,700 |
| | | SUPPLEMENTAL DATA | | Cyclical Exemption W | | 5 | | RES LAND | 1010 | 399,700 | 399,700 |
| | | Alt Prcl ID Scnd Home Tax Class T Tot Fin Area 2507 Total Acres .4 Chapter Lan GIS ID F_875021_2843791 | | District Res Exem | | | | RESIDNTL | 1010 | 20,500 | 20,500 |
| | | | | Assoc Pid# | | | | Total | | 813,900 | 813,900 |

VISION

| RECORD OF OWNERSHIP | | BK-VOL/PAGE | SALE DATE | Q/U | V/I | SALE PRICE | VC | PREVIOUS ASSESSMENTS (HISTORY) | | | | | | | | |
|-----------------------------------|--|-------------|------------|-----|-----|------------|----|--------------------------------|------|----------|-------|------|----------|-------|------|----------|
| STRAVIN MICHAEL C | | 47036 0151 | 06-10-2016 | Q | I | 710,000 | 00 | Year | Code | Assessed | Year | Code | Assessed | Year | Code | Assessed |
| KISPERT DAVID M & KISPERT JULIA R | | 4646 0311 | 01-01-2001 | U | I | 73,000 | 1 | 2023 | 1010 | 390,900 | 2022 | 1010 | 352,000 | 2021 | 1010 | 350,100 |
| | | | | | | | | | 1010 | 428,600 | | 1010 | 277,000 | | 1010 | 263,500 |
| | | | | | | | | | 1010 | 8,500 | | 1010 | 8,500 | | 1010 | 8,500 |
| | | | | | | | | Total | | 828,000 | Total | | 637,500 | Total | | 622,100 |

| EXEMPTIONS | | | OTHER ASSESSMENTS | | | | | |
|------------|------|-------------|-------------------|------|-------------|--------|--------|----------|
| Year | Code | Description | Amount | Code | Description | Number | Amount | Comm Int |
| | | | 0.00 | | | | | |

| ASSESSING NEIGHBORHOOD | | | | |
|------------------------|-----------|---|---------|-------|
| Nbhd | Nbhd Name | B | Tracing | Batch |
| 0060 | | | | |

| BUILDING PERMIT RECORD | | | | | | | | VISIT / CHANGE HISTORY | | | | | | |
|------------------------|------------|------|-------------|---------|------------|--------|-----------|---------------------------|------------|-----|------|----|----|-----------------------|
| Permit Id | Issue Date | Type | Description | Amount | Insp Date | % Comp | Date Comp | Comments | Date | Id | Type | Is | Cd | Purpose/Result |
| 2017-103 | 04-18-2017 | AD | Addition | 150,000 | 05-31-2018 | 100 | | TWO STY ADDITION EACH LEV | 10-30-2019 | SJT | 10 | | 15 | Appointment - No Show |
| 431 | 09-13-2004 | MN | Maintenance | 3,000 | | 100 | | REPL. SLIDER,WINDOWS | 05-31-2018 | JLF | 5 | | 01 | Measure - No Entry |
| 437 | 10-29-2001 | MN | Maintenance | 5,000 | | 100 | | RESHINGLE ROOF | 05-30-2017 | JLF | 5 | | 30 | Quality Control |
| | | | | | | | | | 07-21-2016 | SJD | 9 | 1 | 00 | Measure & Listed |
| | | | | | | | | | 04-12-2013 | VGS | | | 20 | Field Review |
| | | | | | | | | | 10-10-2012 | KP | 6 | | 30 | Quality Control |
| | | | | | | | | | 04-15-2005 | KP | | 1 | 00 | Measure & Listed |

| LAND LINE VALUATION SECTION | | | | | | | | | | | | | | | | |
|-----------------------------|----------|---------------|------|-----------|------------|------------|------------------------|------------|-------|-------|-----------|-------|---------------------|------------|------------|---------|
| B | Use Code | Description | Zone | Land Type | Land Units | Unit Price | Size Adj | Site Index | Cond. | Nbhd. | Nbhd. Adj | Notes | Location Adjustment | Adj Unit P | Land Value | |
| 1 | 1010 | Single Family | RC | Primary | 17,424 SF | 17.11 | 1.00000 | 5 | 1.00 | 0060 | 1.341 | | 1.0000 | 22.94 | 399,700 | |
| Total Card Land Units | | | | | 0.40 | AC | Parcel Total Land Area | | | | | 0.40 | Total Land Value | | | 399,700 |

| CONSTRUCTION DETAIL | | | CONSTRUCTION DETAIL (CONTINUED) | | |
|---------------------|------|----------------|---------------------------------|------|-------------|
| Element | Cd | Description | Element | Cd | Description |
| Style | 11 | Antique | Bsmt Area | 96 | |
| Model | 01 | Residential | Bsmt Type | 03 | |
| Grade | 05 | Ave/Good | Unfin Area | 0.00 | Partial |
| Stories | 1.75 | | | | |
| Occupancy | 1 | | | | |
| Exterior Wall 1 | 14 | Wood Shingle | | | |
| Exterior Wall 2 | 11 | Clapboard | | | |
| Roof Structure | 03 | Gable | | | |
| Roof Cover | 03 | Asphalt | | | |
| Interior Wall 1 | 05 | Drywall | | | |
| Interior Wall 2 | | | | | |
| Interior Floor 1 | 09 | Pine/Soft Wood | | | |
| Interior Floor 2 | 11 | Ceramic | | | |
| Heat Fuel | 03 | Gas | | | |
| Heat Type | 05 | Hot Water | | | |
| AC Type | 03 | Central | | | |
| Bedrooms | 4 | | | | |
| Full Baths | 2 | | | | |
| Half Baths | 1 | | | | |
| Extra Fixtures | 2 | | | | |
| Total Rooms | 8 | | | | |
| Bath Style | 02 | Average | | | |
| Kitchen Style | 01 | Old Style | | | |
| Extra Kitchens | 0 | | | | |
| Fireplaces | 1 | | | | |
| Extra Openings | 2 | | | | |
| Gas Fireplaces | 0 | | | | |
| Sq Ft Fin Bsmt | 0 | | | | |
| FBM Quality | | | | | |
| Foundation | 03 | Stone | | | |
| Bsmt Garage | 0 | | | | |
| Bsmt Area | 96 | | | | |

| CONDO DATA | | | | |
|-------------|------|-------------|---------|------|
| Parcel Id | | C | | Owne |
| | | | B | S |
| Adjust Type | Code | Description | Factor% | |
| Condo Flr | | | | |
| Condo Unit | | | | |

| COST / MARKET VALUATION | |
|--------------------------|---------|
| Net Other Adj | 493,417 |
| Replace Cost | 24,570 |
| Year Built | 517,988 |
| Effective Year Built | 1775 |
| Depreciation Code | 1997 |
| Remodel Rating | VG |
| Year Remodeled | |
| Depreciation % | 24 |
| Functional Obsol | |
| External Obsol | |
| Trend Factor | 1.000 |
| Condition | |
| Condition % | |
| Percent Good | 76 |
| Cns Sect Rcnd | 393,700 |
| Dep % Ovr | |
| Dep Ovr Comment | |
| Misc Imp Ovr | |
| Misc Imp Ovr Comment | |
| Cost to Cure Ovr | |
| Cost to Cure Ovr Comment | |

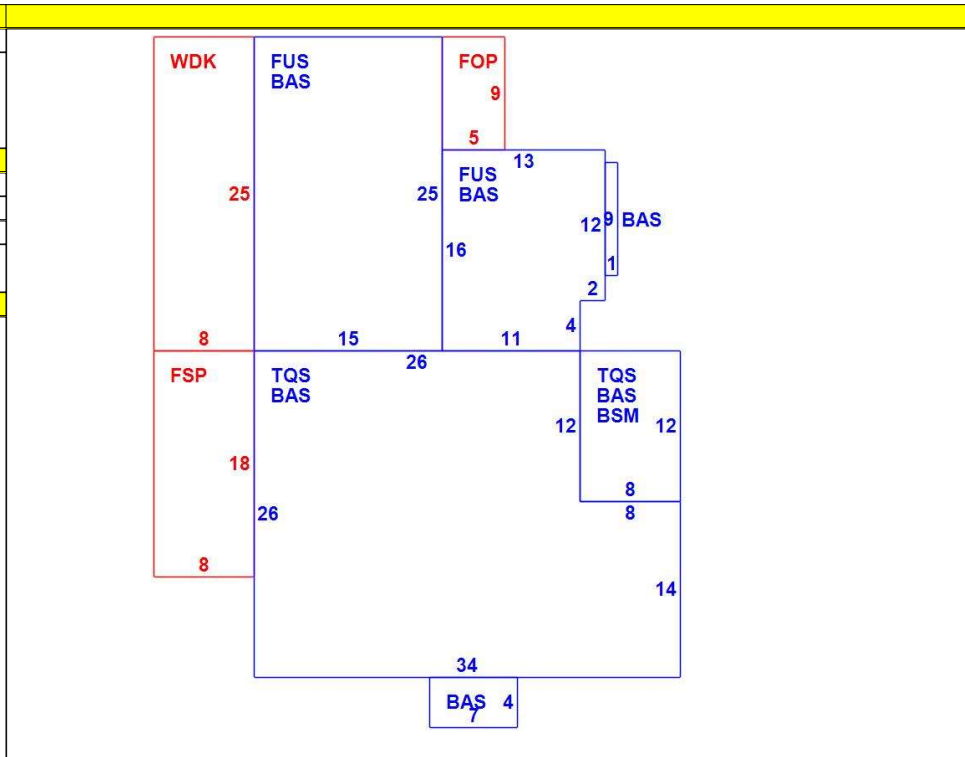

| OB - OUTBUILDING & YARD ITEMS(L) / XF - BUILDING EXTRA FEATURES(B) | | | | | | | | | | |
|--|----------------|-----|-------|------------|--------|----------|------|-------|------------|-------------|
| Code | Description | L/B | Units | Unit Price | Yr Blt | Cond. Cd | % Gd | Grade | Grade Adj. | Appr. Value |
| BRN1 | Barn - 1 Story | L | 432 | 39.00 | 1980 | A | 70 | C | 1.00 | 11,800 |
| GNR | GENERATOR | L | 1 | 12400.00 | 2022 | A | 70 | C | 1.00 | 8,700 |

| BUILDING SUB-AREA SUMMARY SECTION | | | | | | |
|-----------------------------------|----------------------|-------------|------------|----------|-----------|----------------|
| Code | Description | Living Area | Floor Area | Eff Area | Unit Cost | Undeprec Value |
| BAS | First Floor | 1,496 | 1,496 | 1,496 | 175.66 | 262,781 |
| BSM | Basement | 0 | 96 | 19 | 34.77 | 3,337 |
| FOP | Open Porch | 0 | 45 | 7 | 27.32 | 1,230 |
| FSP | Screened Porch | 0 | 144 | 29 | 35.38 | 5,094 |
| FUS | Finished Upper Story | 575 | 575 | 575 | 175.66 | 101,002 |
| TQS | Three Quarter Story | 663 | 884 | 663 | 131.74 | 116,460 |
| WDK | Deck | 0 | 200 | 20 | 17.57 | 3,513 |
| Ttl Gross Liv / Lease Area | | 2,734 | 3,440 | 2,809 | | 493,417 |

